

# The Ekmelos Font

Version 2.54

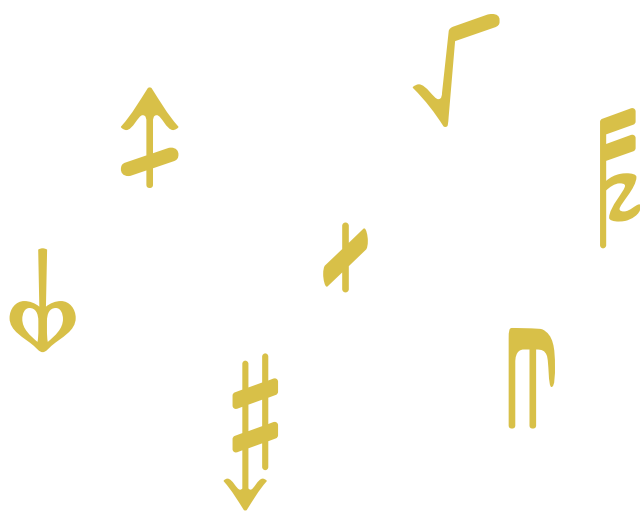

## Contents

---

Foreword . . . . .	4
Download and Installation . . . . .	5
Repertoire . . . . .	6
Sources . . . . .	7
Credits . . . . .	8
License . . . . .	9
Metadata . . . . .	10
LilyPond Support . . . . .	14
Glyph Tables . . . . .	16
Staves . . . . .	17
Staff brackets . . . . .	18
Staff dividers . . . . .	20
Barlines . . . . .	21
Clefs . . . . .	22
Noteheads . . . . .	26
Round and square noteheads . . . . .	30
Slash noteheads . . . . .	31
Shape note noteheads . . . . .	32
Note name noteheads . . . . .	34
Cowell noteheads . . . . .	38
Note clusters . . . . .	39
Individual notes . . . . .	41
Beamed groups of notes . . . . .	44
Metronome marks . . . . .	46
Simplified Music Notation . . . . .	48
Techniques noteheads . . . . .	49
Stems . . . . .	50
Flags . . . . .	51
Accidentals . . . . .	54
Gould arrow quartertone accidentals . . . . .	55
Stein-Zimmermann accidentals . . . . .	56
Stockhausen accidentals (24-EDO) . . . . .	57
Sims accidentals (72-EDO) . . . . .	58
Richter Herf / Maedel accidentals (72-EDO) . . . . .	59
Hesse accidentals (72-EDO) . . . . .	60
Wyschnegradsky accidentals (72-EDO) . . . . .	61
Hába accidentals (24 / 36 / 72-EDO) . . . . .	62
Ferneyhough accidentals . . . . .	63
Johnston accidentals (just intonation) . . . . .	64
Extended Helmholtz-Ellis accidentals (just intonation) . . . . .	66
Arel-Ezgi-Uzdilek (AEU) accidentals . . . . .	69
Turkish folk music accidentals . . . . .	70
Persian accidentals . . . . .	71
Arabic accidentals . . . . .	72
Medieval and Renaissance accidentals . . . . .	73
Sagittal Accidentals . . . . .	74
Other accidentals . . . . .	87
Articulations . . . . .	89

Tremolos . . . . .	92
Rests . . . . .	93
Holds and Pauses . . . . .	94
Repeats and Bar repeats . . . . .	96
Dynamics . . . . .	98
Ornaments . . . . .	100
Combining strokes for trills and mordents . . . . .	102
Precomposed trills and mordents . . . . .	103
Multi-segment Lines . . . . .	104
Wind instruments . . . . .	109
Brass wind instruments . . . . .	111
String instruments . . . . .	113
Plucked techniques . . . . .	115
Chop (percussive bowing) notation . . . . .	116
Guitar . . . . .	117
Chord diagrams . . . . .	118
Harp . . . . .	119
Keyed instruments . . . . .	121
Accordion . . . . .	123
Percussion instruments . . . . .	126
Handbells . . . . .	128
Beaters pictograms . . . . .	129
Percussion pictograms . . . . .	134
Vocals . . . . .	140
Lyrics . . . . .	141
Electronic music . . . . .	142
Communication symbols . . . . .	145
User interface symbols . . . . .	147
Time signatures . . . . .	150
Octaves . . . . .	156
Tuplets . . . . .	157
Fingering . . . . .	158
Chord notation . . . . .	160
Standard accidentals for chord symbols . . . . .	161
Figured bass . . . . .	162
Conductor symbols . . . . .	164
Kodály hand signs . . . . .	165
Analytics . . . . .	166
Function theory symbols . . . . .	167
Scale degrees . . . . .	169
Metrical symbols . . . . .	170
Arrows . . . . .	171
Multiple arrows . . . . .	176
Bent and curved arrows . . . . .	177
Circle and arc arrows . . . . .	178
Arrowheads . . . . .	179
Stars and marks . . . . .	181
Geometric shapes . . . . .	183
Miscellaneous symbols . . . . .	187
Basic Latin (ASCII) . . . . .	189
Spaces . . . . .	192

## Foreword

---

Ekmelos is a music font compliant with [SMuFL](#) .

It includes over 3000 glyphs - clefs, noteheads, accidentals, articulations, ornaments, playing techniques, etc. The focus is on the numerous accidentals for microtonal music, particularly for use along with [Ekmeliily](#) (see [LilyPond Support](#)) which initiated the development of Ekmelos.

The Ekmelos Font Software is a family consisting of four fonts:

- Ekmelos

- Ekmelos 12-EDO

- Ekmelos 24-EDO

- Ekmelos 72-EDO

The N-EDO fonts are extracts including mainly accidentals for the respective EDO, intended for use on Web pages (e.g. with [ekmelib](#) ) to reduce the download volume.

Ekmelos is created with [FontForge](#) .

2 April 2024

## Download and Installation

---

### Download

The folder `fonts` contains the available font files.

Install the OpenType font `otf/EkmeLos.otf` on your system:

- On GNU/Linux: Copy the file e.g. to `/usr/local/share/fonts` (or a subfolder), and rebuild the font cache with `fc-cache -f -v` (or reboot).
- On OS X: Copy the file to `/Library/Fonts`.
- On Windows: Drag the file to `C:\Windows\Fonts` or run the Windows Setup.

## Repertoire

---

The latest release 2.54 implements 3565 glyphs.

It includes some Optional Glyphs:

- SMuFL recommended stylistic alternates and ligatures starting at code point U+F400.
- Ekmelos specific supplements starting at code point U+F600, among others:
  - accidentals by Franz Richter Herf and Rolf Maedel (72-EDO),
  - accidentals by Horst-Peter Hesse (72-EDO),
  - accidentals by Alois Hába for 1/3-, 1/6-, and 1/12-tones,
  - accidentals by Brian Ferneyhough for 1/5-tones,
  - additional Helmholtz-Ellis equal tempered accidentals,
  - some symbols available in [LilyPond](#) but not included in SMuFL.

It additionally includes [Unicode](#) glyphs from the following blocks:

- Musical Symbols: Glyphs corresponding to SMuFL.
- Basic Latin (ASCII), Latin-1 Supplement: For use as textual alternatives to accidentals like in the HEWM notation, and in the Sagittal Pure-long and Mixed-short ASCII representation.
- General Punctuation: Space glyphs.
- Arrows, Supplemental Arrows-A/B: Simple arrows, arrows with bent tips, circle arrows, paired arrows, double arrows, triple arrows, squiggle arrows, dashed arrows, white arrows, keyboard symbols, long arrows, curved arrows.
- Mathematical Operators: Infinity, relations, sine wave.
- Miscellaneous Technical: User interface symbols, keyboard symbols, metrical symbols.
- Block Elements: Full block, shade characters.
- Geometric Shapes: Squares, rectangles, triangles, pointers, diamonds, lozenge, circles, circular arcs.
- Miscellaneous Symbols: Musical symbols, stars, flags, circles, etc.
- Dingbats: Stars, asterisks, question marks, exclamation marks, arrows, curly loops, etc.
- Miscellaneous Symbols and Arrows: Squares, diamonds, pentagons, hexagons, circles, keyboard symbols, stars, cusp shapes, black arrows, white arrows, arrows with bent tips, (paired) triangle-headed arrows, equilateral arrowheads, two-headed arrows.
- Miscellaneous/Supplemental Symbols and Pictographs: Musical symbols, entertainment symbols, audio and video symbols, user interface symbols, communication symbols, sound symbols, office symbols, musical instruments.

On the other hand, ancient (Medieval, Renaissance etc.) symbols are not implemented.

## Sources

---

- SMuFL – Standard Music Font Layout, Version 1.4, 2021. A specification for music symbols, introduced by Daniel Spreadbury and developed by the [W3C Music Notation Community Group](http://www.w3c.org/2011/music-notation/) , [www.smufl.org](http://www.smufl.org) , [github.com/w3c/smufl](https://github.com/w3c/smufl) .
- Bravura music font, Version 1.393, Steinberg Media Technologies GmbH, 2013, 2021. A Unicode typeface designed by Daniel Spreadbury et al., [github.com/steinbergmedia/bravura](https://github.com/steinbergmedia/bravura) .
- The Unicode Standard – Archived Code Charts, Version 8.0, 2015 Unicode, Inc. [home.unicode.org](http://home.unicode.org) .
- Rolf Maedel, Franz Richter Herf: Ekmelische Musik. In: Schriften der Hochschule Mozarteum. No. 4, Katzbichler, München/Salzburg 1977, ISBN 3-87397-473-8. Notation of Ekmelic Music at [www.ekmelic-music.org/en/em/notation.htm](http://www.ekmelic-music.org/en/em/notation.htm) .
- Horst-Peter Hesse: Breaking into a New World of Sound: Reflections on the Ekmelic Music of the Austrian Composer Franz Richter Herf (1920-1989). In: Perspectives of New Music, Volume 29 Number 1, Winter 1991.
- George D. Secor, David C. Keenan: Sagittal – A Microtonal Notation System. 2006, 2012, April 2020. [sagittal.org](http://sagittal.org) .
- LilyPond – the GNU music typesetter, Version 2.22. [lilypond.org](http://lilypond.org) .
- Joe Monzo: Tonalsoft – Encyclopedia of Microtonal Music Theory. HEWM (Helmholtz / Ellis / Wolf / Monzo) notation. [www.tonalsoft.com/enc/h/hewm.aspx](http://www.tonalsoft.com/enc/h/hewm.aspx) .
- Suzette Mary Battan: Alois Hába's Neue Harmonielehre des diatonischen, chromatischen, Viertel-, Drittel-, Sechstel- und Zwölftel-Tonsystems. University of Rochester, Rochester, New York 1980. Fig. 8. from Alois Hába: Harmonické základy čtvrttónové soustavy, 1922. Fig. 13. from Alois Hába: Neue Harmonielehre, 1925, pub. 1927.
- Gardner Read: 20th-Century Microtonal Notation. p.122, from Brian Ferneyhough: Unity Capsule (1975).
- Kyle Gann: The Arithmetic of Listening: Tuning Theory and History for the Impractical Musician. p.212, EX. 13.9: Hába, notation for Suite for Violoncello.
- Simplified Music Notation. Creative Arts Research, 2008. [www.simplifiedmusicnotation.org](http://www.simplifiedmusicnotation.org) .
- Casey Driessen, Oriol Saña: The Chop Notation Project. [www.caseydriessen.com/chop-notation-project](http://www.caseydriessen.com/chop-notation-project) .
- Norman Weinberg: Guide to Standardized Drumset Notation. p.7, Ex. 16 Bell and Edge of Cymbal Notation. [www.normanweinberg.com/uploads/8/1/6/4/81640608/940506pn\\_guildines\\_for\\_drumset.pdf](http://www.normanweinberg.com/uploads/8/1/6/4/81640608/940506pn_guildines_for_drumset.pdf) .
- Dell Technologies: Symbols on Sound Jacks. 2021 Dell Inc. [www.dell.com/community/Desktops-General-Read-Only/Symbols-on-Sound-Jacks/td-p/3917790](http://www.dell.com/community/Desktops-General-Read-Only/Symbols-on-Sound-Jacks/td-p/3917790) .

## Credits

---

Thanks to Daniel Spreadbury, the initiator of [SMuFL](#) and main designer of the Bravura font, and to the whole community developing all that.

Thanks to Gregory Evans for suggestions of additional Helmholtz-Ellis equal tempered accidentals.

Thanks to Taka Minato providing material on the accidentals by Alois Hába (24/72-EDO) and Brian Ferneyhough (1/5-tones).

Ekmelos is designed using the excellent and libre software [FontForge](#) by George Williams et al.



## License

---

Copyright © 2013-2024 Thomas Richter ,  
with Reserved Font Name "Ekmelos" .

This Font Software is licensed under the [SIL Open Font License](#) , Version 1.1.

This license is copied below, and is also available with a FAQ in the files `LICENSE.txt` and `OFL-FAQ.txt` ,  
and at [scripts.sil.org/OFL](https://scripts.sil.org/OFL) .

SIL OPEN FONT LICENSE Version 1.1 - 26 February 2007

### PREAMBLE

The goals of the Open Font License (OFL) are to stimulate worldwide development of collaborative font projects, to support the font creation efforts of academic and linguistic communities, and to provide a free and open framework in which fonts may be shared and improved in partnership with others.

The OFL allows the licensed fonts to be used, studied, modified and redistributed freely as long as they are not sold by themselves. The fonts, including any derivative works, can be bundled, embedded, redistributed and/or sold with any software provided that any reserved names are not used by derivative works. The fonts and derivatives, however, cannot be released under any other type of license. The requirement for fonts to remain under this license does not apply to any document created using the fonts or their derivatives.

### DEFINITIONS

“Font Software” refers to the set of files released by the Copyright Holder(s) under this license and clearly marked as such. This may include source files, build scripts and documentation.

“Reserved Font Name” refers to any names specified as such after the copyright statement(s).

“Original Version” refers to the collection of Font Software components as distributed by the Copyright Holder(s).

“Modified Version” refers to any derivative made by adding to, deleting, or substituting -- in part or in whole -- any of the components of the Original Version, by changing formats or by porting the Font Software to a new environment.

“Author” refers to any designer, engineer, programmer, technical writer or other person who contributed to the Font Software.

### PERMISSION & CONDITIONS

Permission is hereby granted, free of charge, to any person obtaining a copy of the Font Software, to use, study, copy, merge, embed, modify, redistribute, and sell modified and unmodified copies of the Font Software, subject to the following conditions:

- 1) Neither the Font Software nor any of its individual components, in Original or Modified Versions, may be sold by itself.
- 2) Original or Modified Versions of the Font Software may be bundled, redistributed and/or sold with any software, provided that each copy contains the above copyright notice and this license. These can be included either as stand-alone text files, human-readable headers or in the appropriate machine-readable metadata fields within text or binary files as long as those fields can be easily viewed by the user.
- 3) No Modified Version of the Font Software may use the Reserved Font Name(s) unless explicit written permission is granted by the corresponding Copyright Holder. This restriction only applies to the primary font name as presented to the users.
- 4) The name(s) of the Copyright Holder(s) or the Author(s) of the Font Software shall not be used to promote, endorse or advertise any Modified Version, except to acknowledge the contribution(s) of the Copyright Holder(s) and the Author(s) or with their explicit written permission.
- 5) The Font Software, modified or unmodified, in part or in whole, must be distributed entirely under this license, and must not be distributed under any other license. The requirement for fonts to remain under this license does not apply to any document created using the Font Software.

### TERMINATION

This license becomes null and void if any of the above conditions are not met.

### DISCLAIMER

THE FONT SOFTWARE IS PROVIDED “AS IS”, WITHOUT WARRANTY OF ANY KIND, EXPRESS OR IMPLIED, INCLUDING BUT NOT LIMITED TO ANY WARRANTIES OF MERCHANTABILITY, FITNESS FOR A PARTICULAR PURPOSE AND NONINFRINGEMENT OF COPYRIGHT, PATENT, TRADEMARK, OR OTHER RIGHT. IN NO EVENT SHALL THE COPYRIGHT HOLDER BE LIABLE FOR ANY CLAIM, DAMAGES OR OTHER LIABILITY, INCLUDING ANY GENERAL, SPECIAL, INDIRECT, INCIDENTAL, OR CONSEQUENTIAL DAMAGES, WHETHER IN AN ACTION OF CONTRACT, TORT OR OTHERWISE, ARISING FROM, OUT OF THE USE OR INABILITY TO USE THE FONT SOFTWARE OR FROM OTHER DEALINGS IN THE FONT SOFTWARE.

## Metadata

---

The folder `metadata` contains the following files with metadata for Ekmelos in the [JSON](#) format:

### metadata.json

Provides font-specific metadata for Ekmelos compliant with SMuFL. It includes the following keys:

`fontName`

`fontVersion`

`engravingDefaults`

`glyphsWithAnchors` which includes:

`cutOut` . . . of the bounding box of accidental symbols,

`stem` . . . of noteheads and flags,

`repeatOffset` of combining strokes and multi-segment lines,

`noteheadOrigin` of double whole noteheads.

`glyphsWithAlternates`

`ligatures`

`glyphBBoxes`

`optionalGlyphs`

### classes.json

Corresponds to the SMuFL file of the same name but only with the classes that include glyphs of Ekmelos and the following supplements:

`accidentalsRHM` : Richter Herf / Maedel accidentals for 72-EDO.

`accidentals24EDOHaba` : Alois Hába's accidentals for 24-EDO.

`accidentals72EDOHaba` : Alois Hába's accidentals for 1/3-, 1/6-, and 1/12-tones (72-EDO).

`accidentalsHesse` : Horst-Peter Hesse's accidentals for 72-EDO.

`accidentals31EDOFerneyhough` : Brian Ferneyhough's accidentals for 1/5-tones (31-EDO).

`accidentalsMedRen` : Medieval and Renaissance accidentals.

`accidentalsParenthesised` : Parenthesised standard accidentals.

`noteheadSetParenthesised` : Parenthesised standard noteheads.

`letter number punctuation separator symbol` : Unicode characters for textual alternatives to accidentals. The classes correspond to the Unicode General Categories L, N, P, Z, S.

### glyphnames.json

Corresponds to the SMuFL file of the same name but only with the glyph names of Ekmelos.

The value of the `description` key is either taken from SMuFL, or for a Unicode character, the character name in lowercase, or for a ligature, a comma-separated concatenation of its components' descriptions.

## glyphdata.json

Provides summarized metadata of the glyphs of Ekmelos.

```
{
  "GLYPHNAME":
  {
    "codepoint": "U+CODEPOINT",
    "alternateCodepoint": "U+ALT_CODEPOINT",
    "description": "DESCRIPTION",

    "alternates": [
      {
        "codepoint": "U+SALT_CODEPOINT",
        "name": "SALT_GLYPHNAME"
      },
      ...
    ],
    "alternateOf": "DEFAULT_GLYPHNAME",
    "block": "BLOCK_CODE",
    "classes": [
      "CLASSNAME",
      ...
    ],
    "code": DECIMAL_CODEPOINT,
    "ekmelib": true,
    "ekmelily": true,
    "ligature": [
      "COMPONENT_GLYPHNAME",
      ...
    ],
    "variants": {
      "SCALING": "VARIANT_GLYPHNAME",
      ...
    },
    "variantOf": "STANDARD_GLYPHNAME"
  },
  ...
}
```

`codepoint` , `alternateCodepoint` , `description` : **See** `glyphnames.json`

`alternates` : List of all stylistic alternates. This is defined only if one or more alternates exist.

`alternateOf` : Default glyph for which `GLYPHNAME` is a stylistic alternate. Else it is not defined.

`block` : Code of the Unicode block that includes `GLYPHNAME` :

0000	U+0020 - U+007F	Basic Latin (ASCII)
0080	U+00A0 - U+00FF	Latin-1 Supplement
2000	U+2000 - U+206F	General Punctuation
2190	U+2190 - U+21FF	Arrows
2200	U+2200 - U+22FF	Mathematical Operators
2300	U+2300 - U+23FF	Miscellaneous Technical
2580	U+2580 - U+259F	Block Elements
25A0	U+25A0 - U+25FF	Geometric Shapes
2600	U+2600 - U+26FF	Miscellaneous Symbols
27F0	U+27F0 - U+27FF	Supplemental Arrows-A
2900	U+2900 - U+297F	Supplemental Arrows-B
2B00	U+2B00 - U+2BFF	Miscellaneous Symbols and Arrows
E000	U+E000 - U+F3FF	SMuFL Recommended Characters
F400	U+F400 - U+F8FF	SMuFL Optional Glyphs
1D100	U+1D100 - U+1D1FF	Musical Symbols
1F300	U+1F300 - U+1F5FF	Miscellaneous Symbols and Pictographs

`classes` : List of the classes that include `GLYPHNAME` .

`code` : Codepoint as a numeric value.

`ekmelib` : True if the glyph is used in tunings of `ekmelib` . Else it is not defined.

`ekmelily` : True if the glyph is used in predefined notation styles of `Ekmelily` . Else it is not defined.

`ligature` : List of the ligature components. This is defined only for a ligature.

`variants` : Collection of all size variants, including `GLYPHNAME` itself. This is defined only if one or more size variants exist.

`SCALING` : Size of `VARIANT_ GLYPHNAME` relative to `GLYPHNAME` , as an integer number.

`variantOf` : Standard glyph for which `GLYPHNAME` is a size variant. Else it is not defined.

**Note:** Size variants exist only for `brace` and `reversedBrace` , where `SCALING` specifies the relative height.

## ekmelily.json

Groups the accidental glyphs of Ekmelos according to the tunings and predefined notation styles supported by [Ekmelily](#) .

```
{
  "EDO": {
    "NOTATION": {
      "GLYPHNAME": DEGREE,
      ...
    },
    ...
  },
  ...
}
```

EDO : Equal-temperament tuning: 12 19 24 31 36 48 53 72 .

NOTATION : Predefined notation style: std go sag rhm sims haba et al.

GLYPHNAME : Can appear in multiple tunings and notation styles, possibly representing different degrees.

DEGREE : Degree of the alteration that the glyph represents in the respective EDO and NOTATION .

## ekmelib.json

Groups the glyphs of Ekmelos according to the tunings supported by [ekmelib](#) .

```
{
  "EDO": [
    "GLYPHNAME",
    ...
  ],
  ...
}
```

EDO : Equal-temperament tuning: 12 24 72 .

GLYPHNAME : Can appear in multiple tunings.

## LilyPond Support

---

The folder `ly` contains the following files:

### ekmelos-map.ily

Definitions to access Ekmelos glyphs by name.

```
#(define-public ekmelos-map '(
  ("GLYPHNAME" . CODEPOINT)
  ...
))
```

Scheme alist with the code points in Ekmelos mapped onto glyph names, except for Unicode glyphs with a simple glyph name `uHEXCODE`.

```
\ekm-glyph GLYPHNAME
```

Draw the glyph `GLYPHNAME` as markup. Calls `\musicglyph` if `GLYPHNAME` is not defined.

```
#(ekm-has-glyph? GLYPHNAME)
```

Return `#t` if `GLYPHNAME` is defined.

```
#(ekm-glyphname CODEPOINT)
```

Return the glyph name of `CODEPOINT`, or `#f` if not defined.

### ekmelos-paths.ily

Definitions to draw Ekmelos glyphs as paths. This allows e.g. to produce stand-alone SVG output.

```
#(define-public ekmelos-paths '(
  (CODEPOINT COMMANDLIST)
  ...
))
```

Scheme alist with the glyphs in Ekmelos mapped onto code points, except for glyphs without a contour (i.e. space glyphs and Unicode Musical Symbols defined as reference to SMuFL glyphs).

`COMMANDLIST` describes the path of the glyph with the commands `M l c z`.

```
\ekm-path CODEPOINT
```

Draw the path of `CODEPOINT` as markup, or nothing (empty stencil) if the path is not defined.

Used properties:

- `font-size` (0)
- `thickness` (0)
- `filled` (`#t`)

```
#(ekm-path-stencil CODEPOINT FONTSIZE THICKNESS FILLED)
```

Return a stencil from the path of `CODEPOINT`, or the empty stencil if the path is not defined.

Extensions for [LilyPond](#) that facilitate the use of glyphs from Ekmelos – and basically from any [SMuFL](#) compliant font:

## Ekmelily

Supports variable accidentals and key signatures for the notation of microtonal music in several tunings: 24, 31, 36, 72-EDO, etc.

## Esmuflily

Supports a variety of other music symbols: clefs, time signatures, noteheads, rests, flags, articulations, performance indications, dynamics, etc.

Note: To make use of Ekmelos in [LilyPond](#) prior to 2.24, its font cache i.e. the folder `~/.lilypond-fonts.cache-2` (on Windows `%HOMEPATH%\lilypond-fonts.cache-2`) must be emptied or completely deleted. So at the next execution of LilyPond this cache will be rebuilt from scratch including the new font.

## Glyph Tables

---

In the following tables, the glyphs are grouped based on the [SMuFL](#) ranges and sorted primarily by SMuFL code points. For Optional Glyphs, the code points and glyph names are highlighted:

[SMuFL specific](#)

[Ekmelos specific](#)

A SMuFL glyph is listed with:

- the SMuFL code point,
- the corresponding Unicode code point, if any,
- the SMuFL canonical (or optional) glyph name,
- the EDO numbers *N* of the “Ekmelos *N*-EDO” fonts that include this glyph, if any.

 U+E0A2 U+1D15D noteheadWhole 12 24 72

A stylistic alternate is listed also with:

- the code point of the default glyph with [salt](#) and a number if there exist several alternates.

 U+F43E stringsChangeBowDirectionImposed U+E626 salt 2

A ligature is listed also with:

- the code points of the corresponding character sequence.

 U+F692 articMarcatoTenutoStaccatoAbove  
U+E4AC U+E4A4 U+E4A2

A [Unicode](#) glyph without a corresponding SMuFL glyph is listed with:

- the Unicode code point,
- a description derived from the Unicode character name, or the [AGL](#) name (Basic Latin, Spaces).

 U+1F399 Studio microphone

An accidental is displayed with a horizontal midline:

 U+E2A2 accidentalSims4Down

A symbol on stem (stem decoration) is displayed with a vertical midline:

 U+E232 stockhausenTremolo

A non-printable glyph is displayed as a box with a thin border.

 U+E0A5 U+1D159 noteheadNull



## Staves

---

—	U+E010	U+1D116	staff1Line	
==	U+E011	U+1D117	staff2Lines	
===	U+E012	U+1D118	staff3Lines	
====	U+E013	U+1D119	staff4Lines	
=====	U+E014	U+1D11A	staff5Lines	
=====	U+E015	U+1D11B	staff6Lines	
—	U+E016		staff1LineWide	
==	U+E017		staff2LinesWide	
===	U+E018		staff3LinesWide	
====	U+E019		staff4LinesWide	
=====	U+E01A		staff5LinesWide	12 24 72
=====	U+E01B		staff6LinesWide	
-	U+E01C		staff1LineNarrow	
==	U+E01D		staff2LinesNarrow	
===	U+E01E		staff3LinesNarrow	
====	U+E01F		staff4LinesNarrow	
=====	U+E020		staff5LinesNarrow	
=====	U+E021		staff6LinesNarrow	
—	U+E022		legerLine	12 24 72
—	U+E023		legerLineWide	12 24 72
-	U+E024		legerLineNarrow	

## Staff brackets

{	U+E000	U+1D114	brace
}	U+E001		reversedBrace



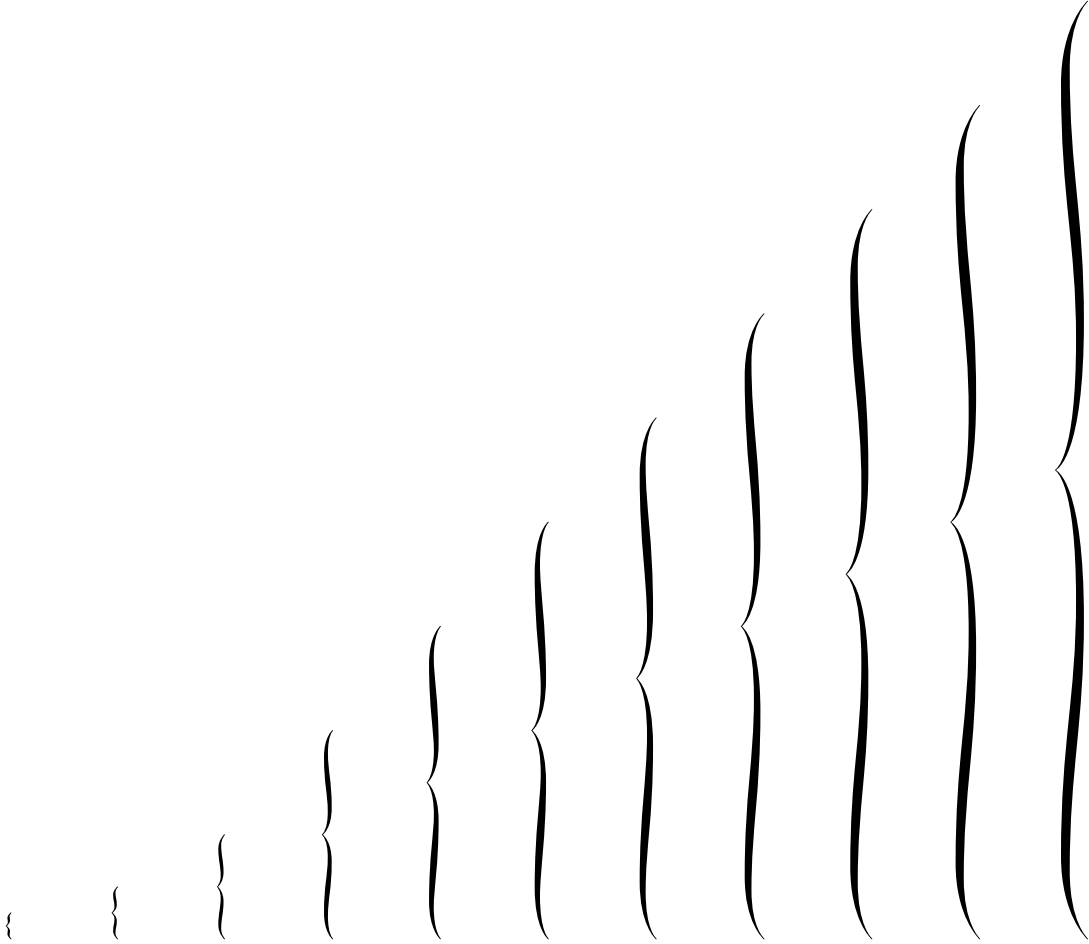









Size variants:









{	{	{	{	{	{	{	{	{	{	{
005	010	020	040	060	080	100	120	140	160	180
F706	E000	F708	F70A	F70C	F70E	F710	F712	F714	F716	F718
F707	E001	F709	F70B	F70D	F70F	F711	F713	F715	F717	F719

The scaling factor NNN is the respective height relative to the brace glyph (U+E000) × 10.  
The glyphnames are braceNNN and reversedBraceNNN.

## Staff brackets

	U+E002	U+1D115	bracket
	U+F643		reversedBracket
	U+E003		bracketTop
	U+E004		bracketBottom
	U+E005		reversedBracketTop
	U+E006		reversedBracketBottom
	U+F700		squareBracket
	U+F703		reversedSquareBracket
	U+F701		squareBracketTop
	U+F702		squareBracketBottom
	U+F704		reversedSquareBracketTop
	U+F705		reversedSquareBracketBottom

## Staff dividers

	U+E007	systemDivider
	U+E008	systemDividerLong
	U+E009	systemDividerExtraLong
	U+E00A	splitBarDivider
	U+E00B	staffDivideArrowDown
	U+E00C	staffDivideArrowUp
	U+E00D	staffDivideArrowUpDown

## Barlines

	U+E030	U+1D100	barlineSingle
	U+E031	U+1D101	barlineDouble
	U+E032	U+1D102	barlineFinal
	U+E033	U+1D103	barlineReverseFinal
	U+E034		barlineHeavy
	U+E035		barlineHeavyHeavy
⋯	U+E036	U+1D104	barlineDashed
⋮	U+E037		barlineDotted
	U+E038	U+1D105	barlineShort
	U+E039		barlineTick













## Clefs

	U+E050	U+1D11E	gClef	12 24 72
	U+E051		gClef15mb	
	U+E052	U+1D120	gClef8vb	
	U+E053	U+1D11F	gClef8va	
	U+E054		gClef15ma	
	U+E055		gClef8vbOld	
	U+E056		gClef8vbCClef	
	U+E057		gClef8vbParens	
	U+E058		gClefLigatedNumberBelow	
	U+E059		gClefLigatedNumberAbove	
	U+E05A		gClefArrowUp	
	U+E05B		gClefArrowDown	
	U+E073		gClefReversed	
	U+E074		gClefTurned	

## Clefs

















	U+E05C	U+1D121	cClef	12 24 72
	U+E05D		cClef8vb	
	U+E05E		cClefArrowUp	
	U+E05F		cClefArrowDown	
	U+E075		cClefReversed	
	U+E060		cClefSquare	
	U+E061		cClefCombining	
	U+F633		cClefFrench20C	
	U+E062	U+1D122	fClef	12 24 72
	U+E063		fClef15mb	
	U+E064	U+1D124	fClef8vb	
	U+E065	U+1D123	fClef8va	
	U+E066		fClef15ma	
	U+E067		fClefArrowUp	
	U+E068		fClefArrowDown	
	U+E076		fClefReversed	
	U+E077		fClefTurned	

## Clefs

	U+E069	U+1D125	unpitchedPercussionClef1	
	U+E06A	U+1D126	unpitchedPercussionClef2	
	U+F650		unpitchedPercussionClef3	U+E069 salt
	U+E06B		semipitchedPercussionClef1	
	U+E06C		semipitchedPercussionClef2	
	U+ED70		indianDrumClef	
	U+E06D		6stringTabClef	
	U+E06E		4stringTabClef	
	U+F40A		6stringTabClefTall	U+E06D salt 1
	U+F40C		4stringTabClefTall	U+E06E salt 1
	U+F40B		6stringTabClefSerif	U+E06D salt 2
	U+F40D		4stringTabClefSerif	U+E06E salt 2
	U+F61E		6stringTabClefClassic	U+E06D salt 3
	U+F61F		4stringTabClefClassic	U+E06E salt 3
	U+E06F		schaefferClef	
	U+E070		schaefferPreviousClef	
	U+E071		schaefferGClefToFClef	
	U+E072		schaefferFClefToGClef	



























## Clefs































	U+E078	bridgeClef
	U+E079	accdnDiatonicClef
	U+E07F	clefChangeCombining
	U+E07A	gClefChange U+E07F U+E050
	U+F630	gClef8vbOldChange U+E07F U+E055
	U+F631	gClef8vbCClefChange U+E07F U+E056
	U+E07B	cClefChange U+E07F U+E05C
	U+F632	cClefSquareChange U+E07F U+E060
	U+F634	cClefFrench20CChange U+E07F U+F633
	U+E07C	fClefChange U+E07F U+E062
	U+F635	unpitchedPercussionClef1Change U+E07F U+E069
	U+F636	unpitchedPercussionClef2Change U+E07F U+E06A
	U+F651	unpitchedPercussionClef3Change U+E07F U+F650
	U+F6BE	semipitchedPercussionClef1Change U+E07F U+E06B
	U+F6BF	semipitchedPercussionClef2Change U+E07F U+E06C
	U+E07D	clef8
	U+E07E	clef15

## Noteheads



























---

	U+E0A0		noteheadDoubleWhole	
	U+F639		noteheadDoubleWholeAlt	
	U+E0A1		noteheadDoubleWholeSquare	
	U+E0A2	U+1D15D	noteheadWhole	12 24 72
	U+E0A3	U+1D157	noteheadHalf	12 24 72
	U+E0A4	U+1D158	noteheadBlack	12 24 72
	U+F637		noteheadLongaUp	
	U+F638		noteheadLongaDown	
	U+E0A5	U+1D159	noteheadNull	
	U+E0A6		noteheadXDoubleWhole	
	U+E0A7		noteheadXWhole	
	U+E0A8		noteheadXHalf	
	U+E0A9	U+1D143	noteheadXBlack	
	U+E0AA		noteheadXOrnate	
	U+E0AB		noteheadXOrnateEllipse	
	U+E0F8		noteheadHeavyX	
	U+E0F9		noteheadHeavyXHat	
	U+E0B0		noteheadCircleXDoubleWhole	
	U+E0B1		noteheadCircleXWhole	
	U+E0B2		noteheadCircleXHalf	
	U+E0B3	U+1D145	noteheadCircleX	
	U+E0EC		noteheadCircledXLarge	
	U+E0B4		noteheadDoubleWholeWithX	
	U+E0B5		noteheadWholeWithX	
	U+E0B6		noteheadHalfWithX	
	U+E0B7		noteheadVoidWithX	
	U+F680		noteheadBlackWithX	













## Noteheads

	U+E0AC		noteheadPlusDoubleWhole
	U+E0AD		noteheadPlusWhole
	U+E0AE		noteheadPlusHalf
	U+E0AF	U+1D144	noteheadPlusBlack
	U+E0BA		noteheadTriangleUpDoubleWhole
	U+E0BB		noteheadTriangleUpWhole
	U+E0BC		noteheadTriangleUpHalf
	U+E0BD	U+1D148	noteheadTriangleUpWhite
	U+E0BE	U+1D149	noteheadTriangleUpBlack
	U+E0C3		noteheadTriangleDownDoubleWhole
	U+E0C4		noteheadTriangleDownWhole
	U+E0C5		noteheadTriangleDownHalf
	U+E0C6	U+1D14E	noteheadTriangleDownWhite
	U+E0C7	U+1D14F	noteheadTriangleDownBlack
	U+E0ED		noteheadLargeArrowUpDoubleWhole
	U+E0EE		noteheadLargeArrowUpWhole
	U+E0EF		noteheadLargeArrowUpHalf
	U+E0F0		noteheadLargeArrowUpBlack
	U+E0F1		noteheadLargeArrowDownDoubleWhole
	U+E0F2		noteheadLargeArrowDownWhole
	U+E0F3		noteheadLargeArrowDownHalf
	U+E0F4		noteheadLargeArrowDownBlack
	U+F681		noteheadDoubleTriangleUpWhite
	U+F682		noteheadDoubleTriangleUpBlack
	U+E0BF	U+1D14A	noteheadTriangleLeftWhite
	U+E0C0	U+1D14B	noteheadTriangleLeftBlack
	U+E0C1	U+1D14C	noteheadTriangleRightWhite
	U+E0C2	U+1D14D	noteheadTriangleRightBlack
	U+E0C8	U+1D150	noteheadTriangleUpRightWhite
	U+E0C9	U+1D151	noteheadTriangleUpRightBlack

























## Noteheads

	U+E0CA	U+1D152	noteheadMoonWhite	
	U+E0CB	U+1D153	noteheadMoonBlack	
	U+E0CC	U+1D154	noteheadTriangleRoundDownWhite	
	U+E0CD	U+1D155	noteheadTriangleRoundDownBlack	
	U+E0D5		noteheadSlashedDoubleWhole1	
	U+E0D3		noteheadSlashedWhole1	
	U+E0D1		noteheadSlashedHalf1	
	U+E0CF		noteheadSlashedBlack1	
	U+E0D6		noteheadSlashedDoubleWhole2	
	U+E0D4		noteheadSlashedWhole2	
	U+E0D2		noteheadSlashedHalf2	
	U+E0D0		noteheadSlashedBlack2	
	U+E0F7		noteheadCircleSlash	
	U+E0D7		noteheadDiamondDoubleWhole	
	U+E0D8		noteheadDiamondWhole	12 24 72
	U+E0D9		noteheadDiamondHalf	12 24 72
	U+E0DB		noteheadDiamondBlack	12 24 72
	U+E0DD		noteheadDiamondWhite	
	U+E0DA		noteheadDiamondHalfWide	
	U+E0DC		noteheadDiamondBlackWide	
	U+E0DE		noteheadDiamondWhiteWide	
	U+E0DF		noteheadDiamondDoubleWholeOld	
	U+E0E0		noteheadDiamondWholeOld	
	U+E0E1		noteheadDiamondHalfOld	
	U+E0E2		noteheadDiamondBlackOld	
	U+E0E3		noteheadDiamondHalfFilled	
	U+E0FC		noteheadDiamondOpen	











## Noteheads

	U+E0E7		noteheadCircledDoubleWhole
	U+E0E6		noteheadCircledWhole
	U+E0E5		noteheadCircledHalf
	U+E0E4		noteheadCircledBlack
	U+E0EB		noteheadCircledDoubleWholeLarge
	U+E0EA		noteheadCircledWholeLarge
	U+E0E9		noteheadCircledHalfLarge
	U+E0E8		noteheadCircledBlackLarge
( )	U+E0CE	U+1D156	noteheadParenthesis
(	U+E0F5		noteheadParenthesisLeft
)	U+E0F6		noteheadParenthesisRight
[	U+F6EA		noteheadBracketLeft
]	U+F6EB		noteheadBracketRight
{	U+F6EC		noteheadBraceLeft
}	U+F6ED		noteheadBraceRight
<	U+F6EE		noteheadAngleLeft
>	U+F6EF		noteheadAngleRight
	U+F5DF		noteheadDoubleWholeParens U+E0F5 U+E0A0 U+E0F6
	U+F5DE		noteheadWholeParens U+E0F5 U+E0A2 U+E0F6
	U+F5DD		noteheadHalfParens U+E0F5 U+E0A3 U+E0F6
	U+F5DC		noteheadBlackParens U+E0F5 U+E0A4 U+E0F6
	U+E0FA		noteheadWholeFilled
	U+E0FB		noteheadHalfFilled
~	U+EEA0		noteheadNancarrowSine































## Round and square noteheads

	U+E113		noteheadRoundBlack
	U+E114		noteheadRoundWhite
	U+E115		noteheadRoundWhiteWithDot
	U+F67E		noteheadRoundHalfBlack
	U+E110		noteheadRoundBlackLarge
	U+E111		noteheadRoundWhiteLarge
	U+E112		noteheadRoundWhiteWithDotLarge
	U+F67F		noteheadRoundHalfBlackLarge
	U+E118		noteheadRoundBlackSlashed
	U+E119		noteheadRoundWhiteSlashed
	U+E116		noteheadRoundBlackSlashedLarge
	U+E117		noteheadRoundWhiteSlashedLarge
	U+F6F0		noteheadRoundBlackVerticalLine
	U+F6F1		noteheadRoundWhiteVerticalLine
	U+F6F2		noteheadRoundBlackVerticalLineLarge
	U+F6F3		noteheadRoundWhiteVerticalLineLarge
	U+E0B8	U+1D146	noteheadSquareWhite
	U+E0B9	U+1D147	noteheadSquareBlack
	U+F67C		noteheadSquareHalfBlack
	U+E11A		noteheadSquareBlackLarge
	U+E11B		noteheadSquareBlackWhite
	U+F67D		noteheadSquareHalfBlackLarge
	U+E11C		noteheadRoundBlackDoubleSlashed
	U+E11D		noteheadRoundWhiteDoubleSlashed

## Slash noteheads

	U+E10A		noteheadSlashWhiteDoubleWhole
	U+E102		noteheadSlashWhiteWhole
	U+E103		noteheadSlashWhiteHalf
	U+E101	U+1D10D	noteheadSlashHorizontalEnds
	U+E100		noteheadSlashVerticalEnds
	U+E105		noteheadSlashVerticalEndsSmall
	U+E109		noteheadSlashWhiteMuted
	U+E108		noteheadSlashHorizontalEndsMuted
	U+E107		noteheadSlashVerticalEndsMuted
	U+E106		noteheadSlashX
	U+E104		noteheadSlashDiamondWhite

## Shape note noteheads

	U+ECD0	noteShapeRoundDoubleWhole
	U+E1B0	noteShapeRoundWhite
	U+E1B1	noteShapeRoundBlack
	U+ECD1	noteShapeSquareDoubleWhole
	U+E1B2	noteShapeSquareWhite
	U+E1B3	noteShapeSquareBlack
	U+ECD2	noteShapeTriangleRightDoubleWhole
	U+E1B4	noteShapeTriangleRightWhite
	U+E1B5	noteShapeTriangleRightBlack
	U+ECD3	noteShapeTriangleLeftDoubleWhole
	U+E1B6	noteShapeTriangleLeftWhite
	U+E1B7	noteShapeTriangleLeftBlack
	U+ECD4	noteShapeDiamondDoubleWhole
	U+E1B8	noteShapeDiamondWhite
	U+E1B9	noteShapeDiamondBlack
	U+ECD5	noteShapeTriangleUpDoubleWhole
	U+E1BA	noteShapeTriangleUpWhite
	U+E1BB	noteShapeTriangleUpBlack
	U+ECD6	noteShapeMoonDoubleWhole
	U+E1BC	noteShapeMoonWhite
	U+E1BD	noteShapeMoonBlack
	U+ECD7	noteShapeTriangleRoundDoubleWhole
	U+E1BE	noteShapeTriangleRoundWhite
	U+E1BF	noteShapeTriangleRoundBlack
	U+ECD8	noteShapeKeystoneDoubleWhole
	U+E1C0	noteShapeKeystoneWhite
	U+E1C1	noteShapeKeystoneBlack
	U+ECD9	noteShapeQuarterMoonDoubleWhole
	U+E1C2	noteShapeQuarterMoonWhite
	U+E1C3	noteShapeQuarterMoonBlack



## Shape note noteheads

⦿	U+ECDA	noteShapeIsoscelesTriangleDoubleWhole
◁	U+E1C4	noteShapeIsoscelesTriangleWhite
◀	U+E1C5	noteShapeIsoscelesTriangleBlack
◐	U+ECDB	noteShapeMoonLeftDoubleWhole
◑	U+E1C6	noteShapeMoonLeftWhite
◒	U+E1C7	noteShapeMoonLeftBlack
◀	U+ECDC	noteShapeArrowheadLeftDoubleWhole
◁	U+E1C8	noteShapeArrowheadLeftWhite
◂	U+E1C9	noteShapeArrowheadLeftBlack
◐	U+ECDD	noteShapeTriangleRoundLeftDoubleWhole
◑	U+E1CA	noteShapeTriangleRoundLeftWhite
◒	U+E1CB	noteShapeTriangleRoundLeftBlack

## Note name noteheads

♩	U+E150	noteDoWhole
♪	U+E158	noteDoHalf
♫	U+E160	noteDoBlack
♮	U+E151	noteReWhole
♭	U+E159	noteReHalf
♭	U+E161	noteReBlack
♯	U+E152	noteMiWhole
♯	U+E15A	noteMiHalf
♯	U+E162	noteMiBlack
♮	U+E153	noteFaWhole
♮	U+E15B	noteFaHalf
♮	U+E163	noteFaBlack
♮	U+E154	noteSoWhole
♮	U+E15C	noteSoHalf
♮	U+E164	noteSoBlack
♮	U+E155	noteLaWhole
♮	U+E15D	noteLaHalf
♮	U+E165	noteLaBlack
♮	U+E157	noteSiWhole
♮	U+E15F	noteSiHalf
♮	U+E167	noteSiBlack
♮	U+E156	noteTiWhole
♮	U+E15E	noteTiHalf
♮	U+E166	noteTiBlack

## Note name noteheads

Ⓐ	U+E169	noteAWhole
♮	U+E180	noteAHalf
♩	U+E197	noteABlack
♭	U+E168	noteAFlatWhole
♮	U+E17F	noteAFlatHalf
♭	U+E196	noteAFlatBlack
♯	U+E16A	noteASharpWhole
♮	U+E181	noteASharpHalf
♯	U+E198	noteASharpBlack
Ⓑ	U+E16C	noteBWhole
♮	U+E183	noteBHalf
♩	U+E19A	noteBBlack
♭	U+E16B	noteBFlatWhole
♮	U+E182	noteBFlatHalf
♭	U+E199	noteBFlatBlack
♯	U+E16D	noteBSharpWhole
♮	U+E184	noteBSharpHalf
♯	U+E19B	noteBSharpBlack
Ⓒ	U+E16F	noteCWhole
♮	U+E186	noteCHalf
♩	U+E19D	noteCBlack
♭	U+E16E	noteCFlatWhole
♮	U+E185	noteCFlatHalf
♭	U+E19C	noteCFlatBlack
♯	U+E170	noteCSharpWhole
♮	U+E187	noteCSharpHalf
♯	U+E19E	noteCSharpBlack

## Note name noteheads

Ⓓ	U+E172	noteDWhole
⓪	U+E189	noteDHalf
Ⓧ	U+E1A0	noteDBlack
Ⓓ̂	U+E171	noteDFlatWhole
⓪̂	U+E188	noteDFlatHalf
Ⓧ̂	U+E19F	noteDFlatBlack
Ⓓ♯	U+E173	noteDSharpWhole
⓪♯	U+E18A	noteDSharpHalf
Ⓧ♯	U+E1A1	noteDSharpBlack
Ⓔ	U+E175	noteEWhole
⓪	U+E18C	noteEHalf
Ⓧ	U+E1A3	noteEBlack
Ⓔ̂	U+E174	noteEFlatWhole
⓪̂	U+E18B	noteEFlatHalf
Ⓧ̂	U+E1A2	noteEFlatBlack
Ⓔ♯	U+E176	noteESharpWhole
⓪♯	U+E18D	noteESharpHalf
Ⓧ♯	U+E1A4	noteESharpBlack
Ⓕ	U+E178	noteFWhole
⓪	U+E18F	noteFHalf
Ⓧ	U+E1A6	noteFBlack
Ⓕ̂	U+E177	noteFFlatWhole
⓪̂	U+E18E	noteFFlatHalf
Ⓧ̂	U+E1A5	noteFFlatBlack
Ⓕ♯	U+E179	noteFSharpWhole
⓪♯	U+E190	noteFSharpHalf
Ⓧ♯	U+E1A7	noteFSharpBlack

























## Note name noteheads

Ⓒ	U+E17B	noteGWhole
Ⓓ	U+E192	noteGHalf
Ⓔ	U+E1A9	noteGBlack
Ⓖ	U+E17A	noteGFlatWhole
Ⓗ	U+E191	noteGFlatHalf
Ⓙ	U+E1A8	noteGFlatBlack
Ⓚ	U+E17C	noteGSharpWhole
Ⓛ	U+E193	noteGSharpHalf
Ⓜ	U+E1AA	noteGSharpBlack
Ⓕ	U+E17D	noteHWhole
Ⓖ	U+E194	noteHHalf
Ⓗ	U+E1AB	noteHBlack
Ⓖ	U+F720	noteHFlatWhole
Ⓗ	U+F721	noteHFlatHalf
Ⓖ	U+F722	noteHFlatBlack
Ⓖ	U+E17E	noteHSharpWhole
Ⓗ	U+E195	noteHSharpHalf
Ⓖ	U+E1AC	noteHSharpBlack
●	U+E1AD	noteEmptyWhole
●	U+E1AE	noteEmptyHalf
●	U+E1AF	noteEmptyBlack

## Cowell noteheads

△	U+EEA1	noteheadCowellThirdNoteSeriesWhole
△	U+EEA2	noteheadCowellThirdNoteSeriesHalf
▲	U+EEA3	noteheadCowellThirdNoteSeriesBlack
▣	U+EEA4	noteheadCowellFifthNoteSeriesWhole
▣	U+EEA5	noteheadCowellFifthNoteSeriesHalf
■	U+EEA6	noteheadCowellFifthNoteSeriesBlack
◇	U+EEA7	noteheadCowellSeventhNoteSeriesWhole
◇	U+EEA8	noteheadCowellSeventhNoteSeriesHalf
◆	U+EEA9	noteheadCowellSeventhNoteSeriesBlack
▣	U+EEAA	noteheadCowellNinthNoteSeriesWhole
▣	U+EEAB	noteheadCowellNinthNoteSeriesHalf
■	U+EEAC	noteheadCowellNinthNoteSeriesBlack
⊠	U+EEAD	noteheadCowellEleventhNoteSeriesWhole
⊠	U+EEAE	noteheadCowellEleventhNoteSeriesHalf
⊠	U+EEAF	noteheadCowellEleventhSeriesBlack
⊠	U+EEB0	noteheadCowellThirteenthNoteSeriesWhole
⊠	U+EEB1	noteheadCowellThirteenthNoteSeriesHalf
⊠	U+EEB2	noteheadCowellThirteenthNoteSeriesBlack
⊠	U+EEB3	noteheadCowellFifteenthNoteSeriesWhole
⊠	U+EEB4	noteheadCowellFifteenthNoteSeriesHalf
■	U+EEB5	noteheadCowellFifteenthNoteSeriesBlack

## Note clusters



















	U+E120	U+1D15A	noteheadClusterSquareWhite
	U+E121	U+1D15B	noteheadClusterSquareBlack
	U+E122		noteheadClusterRoundWhite
	U+E123		noteheadClusterRoundBlack
	U+E124		noteheadClusterDoubleWhole2nd
	U+E128		noteheadClusterDoubleWhole3rd
	U+E12C		noteheadClusterDoubleWholeTop
	U+E12D		noteheadClusterDoubleWholeMiddle
	U+E12E		noteheadClusterDoubleWholeBottom
	U+E125		noteheadClusterWhole2nd
	U+E129		noteheadClusterWhole3rd
	U+E12F		noteheadClusterWholeTop
	U+E130		noteheadClusterWholeMiddle
	U+E131		noteheadClusterWholeBottom
	U+E126		noteheadClusterHalf2nd
	U+E12A		noteheadClusterHalf3rd
	U+E132		noteheadClusterHalfTop
	U+E133		noteheadClusterHalfMiddle
	U+E134		noteheadClusterHalfBottom
	U+E127		noteheadClusterQuarter2nd
	U+E12B		noteheadClusterQuarter3rd
	U+E135		noteheadClusterQuarterTop
	U+E136		noteheadClusterQuarterMiddle
	U+E137		noteheadClusterQuarterBottom

## Note clusters













◇	U+E138	noteheadDiamondClusterWhite2nd
◇	U+E13A	noteheadDiamondClusterWhite3rd
◇	U+E13C	noteheadDiamondClusterWhiteTop
„	U+E13D	noteheadDiamondClusterWhiteMiddle
∨	U+E13E	noteheadDiamondClusterWhiteBottom
◇	U+F64B	noteheadDiamondClusterHalf2nd
◇	U+F64C	noteheadDiamondClusterHalf3rd
◇	U+F64D	noteheadDiamondClusterHalfTop
„	U+F64E	noteheadDiamondClusterHalfMiddle
∨	U+F64F	noteheadDiamondClusterHalfBottom
◆	U+E139	noteheadDiamondClusterBlack2nd
◆	U+E13B	noteheadDiamondClusterBlack3rd
◆	U+E13F	noteheadDiamondClusterBlackTop
■	U+E140	noteheadDiamondClusterBlackMiddle
◆	U+E141	noteheadDiamondClusterBlackBottom
□	U+E145	noteheadRectangularClusterWhiteTop
„	U+E146	noteheadRectangularClusterWhiteMiddle
□	U+E147	noteheadRectangularClusterWhiteBottom
■	U+E142	noteheadRectangularClusterBlackTop
■	U+E143	noteheadRectangularClusterBlackMiddle
■	U+E144	noteheadRectangularClusterBlackBottom











## Individual notes

	U+E1D0	U+1D15C	noteDoubleWhole
	U+E1D1		noteDoubleWholeSquare
	U+E1D2	U+1D15D	noteWhole
	U+E1D3	U+1D15E	noteHalfUp
	U+E1D4		noteHalfDown
	U+E1D5	U+1D15F	noteQuarterUp
	U+E1D6		noteQuarterDown
	U+E1D7	U+1D160	note8thUp
	U+E1D8		note8thDown
	U+E1D9	U+1D161	note16thUp
	U+E1DA		note16thDown
	U+E1DB	U+1D162	note32ndUp
	U+E1DC		note32ndDown
	U+E1DD	U+1D163	note64thUp
	U+E1DE		note64thDown
	U+E1DF	U+1D164	note128thUp
	U+E1E0		note128thDown
	U+E1E1		note256thUp
	U+E1E2		note256thDown





















## Individual notes

	U+E1E3		note512thUp	
	U+E1E4		note512thDown	
	U+E1E5		note1024thUp	
	U+E1E6		note1024thDown	
	U+E1E7	U+1D16D	augmentationDot	12 24 72
	U+F614		noteTick	12 24 72
	U+F683		note8thUpStraight	U+E1D7 salt 1
	U+F686		note16thUpStraight	U+E1D9 salt 1
	U+F689		note32ndUpStraight	U+E1DB salt 1
	U+F684		note8thUpShort	U+E1D7 salt 2
	U+F687		note16thUpShort	U+E1D9 salt 2
	U+F68A		note32ndUpShort	U+E1DB salt 2
	U+F685		note8thUpBeamed	U+E1D7 salt 3
	U+F688		note16thUpBeamed	U+E1D9 salt 3
	U+F68B		note32ndUpBeamed	U+E1DB salt 3

## Individual notes

	U+2669	Quarter note
	U+266A	Eighth note
	U+266B	Beamed eighth notes
	U+266C	Beamed sixteenth notes
	U+1F39C	Beamed ascending notes
	U+1F39D	Beamed descending notes
	U+1F3B5	Music, Mood
	U+1F3B6	Dancing notes, Mood, Melody
	U+1F3BC	Musical score

## Beamed groups of notes

	U+E1F0	textBlackNoteShortStem
	U+E1F1	textBlackNoteLongStem
	U+E1F2	textBlackNoteFrac8thShortStem
	U+E1F3	textBlackNoteFrac8thLongStem
	U+E1F4	textBlackNoteFrac16thShortStem
	U+E1F5	textBlackNoteFrac16thLongStem
	U+E1F6	textBlackNoteFrac32ndLongStem
	U+E1F7	textCont8thBeamShortStem
	U+E1F8	textCont8thBeamLongStem
	U+E1F9	textCont16thBeamShortStem
	U+E1FA	textCont16thBeamLongStem
	U+E1FB	textCont32ndBeamLongStem
	U+E204	textHeadlessBlackNoteShortStem
	U+E205	textHeadlessBlackNoteLongStem
	U+E206	textHeadlessBlackNoteFrac8thShortStem
	U+E207	textHeadlessBlackNoteFrac8thLongStem
	U+E208	textHeadlessBlackNoteFrac16thShortStem
	U+E209	textHeadlessBlackNoteFrac16thLongStem
	U+E20A	textHeadlessBlackNoteFrac32ndLongStem
	U+E1FC	textAugmentationDot
	U+E1FD	textTie

## Beamed groups of notes

┌	U+E1FE	textTupletBracketStartShortStem
3		
└	U+E1FF	textTuplet3ShortStem
┌	U+E200	textTupletBracketEndShortStem
3	U+E201	textTupletBracketStartLongStem
└	U+E202	textTuplet3LongStem
	U+E203	textTupletBracketEndLongStem

## Examples:



U+E1F0 textBlackNoteShortStem  
 U+E1F7 textCont8thBeamShortStem  
 U+E1F2 textBlackNoteFrac8thShortStem  
 U+E1F9 textCont16thBeamShortStem  
 U+E1F4 textBlackNoteFrac16thShortStem

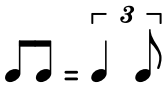





















U+E1F0 textBlackNoteShortStem  
 U+E1F7 textCont8thBeamShortStem  
 U+E1F2 textBlackNoteFrac8thShortStem  
 U+0020 space  
 U+003D equal  
 U+0020 space  
 U+E1F0 textBlackNoteShortStem  
 U+E201 textTupletBracketStartLongStem  
 U+0020 space  
 U+E202 textTuplet3LongStem  
 U+E1D7 note8thUp  
 U+E203 textTupletBracketEndLongStem



U+E1F0 textBlackNoteShortStem  
 U+E1F7 textCont8thBeamShortStem  
 U+E1FC textAugmentationDot  
 U+E1F7 textCont8thBeamShortStem  
 U+E1F4 textBlackNoteFrac16thShortStem

## Metronome marks

	U+ECA0	metNoteDoubleWhole
	U+ECA1	metNoteDoubleWholeSquare
	U+ECA2	metNoteWhole
	U+ECA3	metNoteHalfUp
	U+ECA4	metNoteHalfDown
	U+ECA5	metNoteQuarterUp
	U+ECA6	metNoteQuarterDown
	U+ECA7	metNote8thUp
	U+ECA8	metNote8thDown
	U+ECA9	metNote16thUp
	U+ECAA	metNote16thDown
	U+ECAB	metNote32ndUp
	U+ECAC	metNote32ndDown
	U+ECAD	metNote64thUp
	U+ECAE	metNote64thDown
	U+ECAF	metNote128thUp
	U+ECB0	metNote128thDown
	U+ECB1	metNote256thUp
	U+ECB2	metNote256thDown
	U+ECB3	metNote512thUp
	U+ECB4	metNote512thDown

## Metronome marks



U+ECB5

metNote1024thUp



U+ECB6

metNote1024thDown



U+ECB7

metAugmentationDot

## Simplified Music Notation

◄	U+EC50	smnSharp
►	U+EC59	smnSharpDown
◁	U+EC51	smnSharpWhite
▷	U+EC5A	smnSharpWhiteDown
♭	U+EC52	smnFlat
♮	U+EC53	smnFlatWhite
♯	U+EC54	smnHistorySharp
♯♯	U+EC55	smnHistoryDoubleSharp
♮♭	U+EC56	smnHistoryFlat
♮♮	U+EC57	smnHistoryDoubleFlat
♮	U+EC58	smnNatural



## Techniques noteheads

●	U+EE70	swissRudimentsNoteheadBlackFlam
◌	U+EE71	swissRudimentsNoteheadHalfFlam
●	U+EE72	swissRudimentsNoteheadBlackDouble
◌	U+EE73	swissRudimentsNoteheadHalfDouble

## Stems

---

	U+E210	U+1D165	stem
✱	U+E211	U+1D166	stemSprechgesang
↗	U+E212		stemSwished
✱	U+E213		stemPendereckiTremolo
↑	U+E214		stemSulPonticello
↑	U+E215		stemBowOnBridge
⊥	U+E216		stemBowOnTailpiece
⊥	U+E217		stemBuzzRoll
⊕	U+E218		stemDamp
↻	U+E219		stemVibratoPulse
⚡	U+E21A		stemMultiphonicsBlack
⚡	U+E21B		stemMultiphonicsWhite
⚡	U+E21C		stemMultiphonicsBlackWhite
⌘	U+E21D		stemSussurando
✱	U+E21E		stemRimShot
⚡	U+E21F		stemHarpStringNoise

















## Flags

U+E240	U+1D16E	flag8thUp	12 24 72
U+E241		flag8thDown	12 24 72
U+E242	U+1D16F	flag16thUp	12 24 72
U+E243		flag16thDown	12 24 72
U+E244	U+1D170	flag32ndUp	12 24 72
U+E245		flag32ndDown	12 24 72
U+E246	U+1D171	flag64thUp	12 24 72
U+E247		flag64thDown	12 24 72
U+E248	U+1D172	flag128thUp	
U+E249		flag128thDown	
U+E24A		flag256thUp	
U+E24B		flag256thDown	
U+E24C		flag512thUp	
U+E24D		flag512thDown	
U+E24E		flag1024thUp	
U+E24F		flag1024thDown	
U+E250		flagInternalUp	
U+E251		flagInternalDown	

## Flags

↘	U+F40F	flag8thUpStraight	U+E240 salt 1
↙	U+F411	flag8thDownStraight	U+E241 salt 1
↘↘	U+F412	flag16thUpStraight	U+E242 salt 1
↙↙	U+F414	flag16thDownStraight	U+E243 salt 1
↘↘↘	U+F415	flag32ndUpStraight	U+E244 salt 1
↙↙↙	U+F417	flag32ndDownStraight	U+E245 salt 1
↘↘↘↘	U+F418	flag64thUpStraight	U+E246 salt 1
↙↙↙↙	U+F41A	flag64thDownStraight	U+E247 salt 1
↘↘↘↘↘	U+F41B	flag128thUpStraight	U+E248 salt 1
↙↙↙↙↙	U+F41D	flag128thDownStraight	U+E249 salt 1
↘↘↘↘↘↘	U+F41E	flag256thUpStraight	U+E24A salt 1
↙↙↙↙↙↙	U+F420	flag256thDownStraight	U+E24B salt 1
↘↘↘↘↘↘↘	U+F421	flag512thUpStraight	U+E24C salt 1
↙↙↙↙↙↙↙	U+F423	flag512thDownStraight	U+E24D salt 1
↘↘↘↘↘↘↘↘	U+F424	flag1024thUpStraight	U+E24E salt 1
↙↙↙↙↙↙↙↙	U+F426	flag1024thDownStraight	U+E24F salt 1



























## Flags

	U+F410	flag8thUpShort	U+E240 salt 2
	U+F6C0	flag8thDownShort	U+E241 salt 2
	U+F413	flag16thUpShort	U+E242 salt 2
	U+F6C1	flag16thDownShort	U+E243 salt 2
	U+F416	flag32ndUpShort	U+E244 salt 2
	U+F6C2	flag32ndDownShort	U+E245 salt 2
	U+F419	flag64thUpShort	U+E246 salt 2
	U+F6C3	flag64thDownShort	U+E247 salt 2
	U+F41C	flag128thUpShort	U+E248 salt 2
	U+F6C4	flag128thDownShort	U+E249 salt 2
	U+F41F	flag256thUpShort	U+E24A salt 2
	U+F6C5	flag256thDownShort	U+E24B salt 2
	U+F422	flag512thUpShort	U+E24C salt 2
	U+F6C6	flag512thDownShort	U+E24D salt 2
	U+F425	flag1024thUpShort	U+E24E salt 2
	U+F6C7	flag1024thDownShort	U+E24F salt 2















## Accidentals

---







### Standard accidentals

	U+E260	U+266D	accidentalFlat	12 24 72
	U+E261	U+266E	accidentalNatural	12 24 72
	U+E262	U+266F	accidentalSharp	12 24 72
	U+E263	U+1D12A	accidentalDoubleSharp	12 24 72
	U+E264	U+1D12B	accidentalDoubleFlat	12 24 72
	U+E265		accidentalTripleSharp	
	U+E266		accidentalTripleFlat	
	U+F61C		accidentalQuadrupleSharp	
	U+F61D		accidentalQuadrupleFlat	
	U+F4A1		accidentalDoubleFlatJoinedStems	U+E264 salt
	U+F4A2		accidentalTripleFlatJoinedStems	U+E266 salt
	U+E267		accidentalNaturalFlat	
	U+E268		accidentalNaturalSharp	
	U+E269		accidentalSharpSharp	
	U+E26A		accidentalParensLeft	12 24 72
	U+E26B		accidentalParensRight	12 24 72
	U+E26C		accidentalBracketLeft	
	U+E26D		accidentalBracketRight	
	U+F6D4		accidentalBraceLeft	
	U+F6D5		accidentalBraceRight	
	U+F6D6		accidentalAngleLeft	
	U+F6D7		accidentalAngleRight	
	U+F5E0		accidentalFlatParens U+E26A U+E260 U+E26B	
	U+F5E1		accidentalNaturalParens U+E26A U+E261 U+E26B	
	U+F5E2		accidentalSharpParens U+E26A U+E262 U+E26B	
	U+F5E3		accidentalDoubleSharpParens U+E26A U+E263 U+E26B	
	U+F5E4		accidentalDoubleFlatParens U+E26A U+E264 U+E26B	













## Gould arrow quartertone accidentals

	U+E270	U+1D12C	accidentalQuarterToneFlatArrowUp	24 72
	U+E271	U+1D12D	accidentalThreeQuarterTonesFlatArrowDown	24 72
	U+F616		accidentalFlatArrowBoth	
	U+E272	U+1D12E	accidentalQuarterToneSharpNaturalArrowUp	24 72
	U+E273	U+1D12F	accidentalQuarterToneFlatNaturalArrowDown	24 72
	U+F617		accidentalNaturalArrowBoth	
	U+E274	U+1D130	accidentalThreeQuarterTonesSharpArrowUp	24 72
	U+E275	U+1D131	accidentalQuarterToneSharpArrowDown	24 72
	U+F618		accidentalSharpArrowBoth	
	U+E276		accidentalFiveQuarterTonesSharpArrowUp	24 72
	U+E277		accidentalThreeQuarterTonesSharpArrowDown	24 72
	U+E278		accidentalThreeQuarterTonesFlatArrowUp	24 72
	U+E279		accidentalFiveQuarterTonesFlatArrowDown	24 72
	U+E27A		accidentalArrowUp	24 72
	U+E27B		accidentalArrowDown	24 72

## Stein-Zimmermann accidentals

















	U+E280	accidentalQuarterToneFlatStein	
	U+E284	accidentalNarrowReversedFlat	24 72
	U+E281	accidentalThreeQuarterTonesFlatZimmermann	
	U+E285	accidentalNarrowReversedFlatAndFlat	24 72
	U+E282	accidentalQuarterToneSharpStein	24 72
	U+E283	accidentalThreeQuarterTonesSharpStein	24 72

## Extended Stein-Zimmermann accidentals

	U+E290	accidentalReversedFlatArrowUp	
	U+E291	accidentalReversedFlatArrowDown	
	U+E292	accidentalFilledReversedFlatArrowUp	
	U+E293	accidentalFilledReversedFlatArrowDown	
	U+E294	accidentalReversedFlatAndFlatArrowUp	
	U+E295	accidentalReversedFlatAndFlatArrowDown	
	U+E296	accidentalFilledReversedFlatAndFlat	
	U+E297	accidentalFilledReversedFlatAndFlatArrowUp	
	U+E298	accidentalFilledReversedFlatAndFlatArrowDown	
	U+E299	accidentalHalfSharpArrowUp	
	U+E29A	accidentalHalfSharpArrowDown	
	U+E29B	accidentalOneAndAHalfSharpsArrowUp	
	U+E29C	accidentalOneAndAHalfSharpsArrowDown	



## Stockhausen accidentals (24-EDO)

	U+ED50	accidentalRaisedStockhausen
	U+ED51	accidentalLoweredStockhausen
	U+ED52	accidentalFlatRaisedStockhausen
	U+ED53	accidentalFlatLoweredStockhausen
	U+ED54	accidentalNaturalRaisedStockhausen
	U+ED55	accidentalNaturalLoweredStockhausen
	U+ED56	accidentalSharpRaisedStockhausen
	U+ED57	accidentalSharpLoweredStockhausen
		
	U+ED58	accidentalOneQuarterToneSharpStockhausen
	U+ED59	accidentalOneQuarterToneFlatStockhausen
	U+ED5A	accidentalThreeQuarterTonesSharpStockhausen
		
	U+ED5B	accidentalFlatRepeatedSpaceStockhausen
	U+ED5C	accidentalFlatRepeatedLineStockhausen
	U+ED5D	accidentalSharpRepeatedSpaceStockhausen
	U+ED5E	accidentalSharpRepeatedLineStockhausen

## Sims accidentals (72-EDO)

↓	U+E2A0	accidentalSims12Down	72
↓	U+E2A1	accidentalSims6Down	72
√	U+E2A2	accidentalSims4Down	72
↑	U+E2A3	accidentalSims12Up	72
↑	U+E2A4	accidentalSims6Up	72
┘	U+E2A5	accidentalSims4Up	72























## Richter Herf / Maedel accidentals (72-EDO)

↓	U+F600	accidentalRHM12Down	72
↓	U+F601	accidentalRHM6Down	72
↓	U+F602	accidentalRHM4Down	72
↑	U+F603	accidentalRHM12Up	72
↑	U+F604	accidentalRHM6Up	72
↑	U+F605	accidentalRHM4Up	72
—	U+F615	accidentalRHMNatural	



























## Hesse accidentals (72-EDO)

↘	U+F606	accidentalHesse12Down	72
↓	U+F607	accidentalHesse6Down	72
↓	U+F608	accidentalHesse4Down	72
↙	U+F609	accidentalHesse12Up	72
↑	U+F60A	accidentalHesse6Up	72
↑	U+F60B	accidentalHesse4Up	72











## Wyschnegradsky accidentals (72-EDO)

	U+E420	accidentalWyschnegradsky1TwelfthsSharp	72
	U+E421	accidentalWyschnegradsky2TwelfthsSharp	72
	U+E422	accidentalWyschnegradsky3TwelfthsSharp	72
	U+E423	accidentalWyschnegradsky4TwelfthsSharp	72
	U+E424	accidentalWyschnegradsky5TwelfthsSharp	72
	U+E425	accidentalWyschnegradsky6TwelfthsSharp	72
	U+E426	accidentalWyschnegradsky7TwelfthsSharp	72
	U+E427	accidentalWyschnegradsky8TwelfthsSharp	72
	U+E428	accidentalWyschnegradsky9TwelfthsSharp	72
	U+E429	accidentalWyschnegradsky10TwelfthsSharp	72
	U+E42A	accidentalWyschnegradsky11TwelfthsSharp	72
	U+E42B	accidentalWyschnegradsky1TwelfthsFlat	72
	U+E42C	accidentalWyschnegradsky2TwelfthsFlat	72
	U+E42D	accidentalWyschnegradsky3TwelfthsFlat	72
	U+E42E	accidentalWyschnegradsky4TwelfthsFlat	72
	U+E42F	accidentalWyschnegradsky5TwelfthsFlat	72
	U+E430	accidentalWyschnegradsky6TwelfthsFlat	72
	U+E431	accidentalWyschnegradsky7TwelfthsFlat	72
	U+E432	accidentalWyschnegradsky8TwelfthsFlat	72
	U+E433	accidentalWyschnegradsky9TwelfthsFlat	72
	U+E434	accidentalWyschnegradsky10TwelfthsFlat	72
	U+E435	accidentalWyschnegradsky11TwelfthsFlat	72

## Hába accidentals (24 / 36 / 72-EDO)

	U+EE64	accidentalHabaQuarterToneHigher	24
	U+EE65	accidentalHabaFlatQuarterToneHigher	24
	U+EE66	accidentalHabaSharpThreeQuarterTonesHigher	24
	U+EE67	accidentalHabaQuarterToneLower	24
	U+EE68	accidentalHabaSharpQuarterToneLower	24
	U+EE69	accidentalHabaFlatThreeQuarterTonesLower	24
	U+F624	accidentalHabaSharpLowered	
	U+F625	accidentalHabaSharpRaised	
	U+F626	accidentalHabaFlatLowered	
	U+F627	accidentalHabaFlatRaised	
	U+F672	accidentalHabaSixthSharp	
	U+F660	accidentalHaba1TwelfthsSharp	72
	U+F671	accidentalHaba1TwelfthsSharpAlt	
	U+F661	accidentalHaba2TwelfthsSharp	72
	U+F662	accidentalHaba3TwelfthsSharp	72
	U+F663	accidentalHaba4TwelfthsSharp	72
	U+F664	accidentalHaba5TwelfthsSharp	72
	U+F665	accidentalHaba6TwelfthsSharp	72
	U+F666	accidentalHaba7TwelfthsSharp	72
	U+F667	accidentalHaba8TwelfthsSharp	72
	U+F668	accidentalHaba9TwelfthsSharp	72
	U+F669	accidentalHaba10TwelfthsSharp	72
	U+F66A	accidentalHaba11TwelfthsSharp	72
	U+F66B	accidentalHaba1TwelfthsFlat	72
	U+F66C	accidentalHaba2TwelfthsFlat	72
	U+F66D	accidentalHaba3TwelfthsFlat	72
	U+F66E	accidentalHaba4TwelfthsFlat	72
	U+F66F	accidentalHaba5TwelfthsFlat	72
	U+F670	accidentalHaba6TwelfthsFlat	72

## Ferneyhough accidentals

	U+E48A	accidentalOneThirdToneSharpFerneyhough	72
	U+E48B	accidentalOneThirdToneFlatFerneyhough	72
	U+E48C	accidentalTwoThirdTonesSharpFerneyhough	72
	U+E48D	accidentalTwoThirdTonesFlatFerneyhough	72
	U+E48E	accidentalOneQuarterToneSharpFerneyhough	72
	U+E48F	accidentalOneQuarterToneFlatFerneyhough	72
	U+F678	accidentalOneFifthToneSharpFerneyhough	
	U+F679	accidentalTwoFifthTonesSharpFerneyhough	
	U+F67A	accidentalThreeFifthTonesSharpFerneyhough	
	U+F67B	accidentalFourFifthTonesSharpFerneyhough	

## Johnston accidentals (just intonation)

























—+—	U+E2B0	accidentalJohnstonPlus
—-—	U+E2B1	accidentalJohnstonMinus
—└—	U+E2B2	accidentalJohnstonEI
—┐—	U+E2B3	accidentalJohnstonSeven
—↑—	U+E2B4	accidentalJohnstonUp
—↓—	U+E2B5	accidentalJohnstonDown
—13—	U+E2B6	accidentalJohnston13
—EI—	U+E2B7	accidentalJohnston31
—#—	U+F5E5	accidentalSharpJohnstonEI U+E262 U+E2B2
—#↑—	U+F5E6	accidentalSharpJohnstonUp U+E262 U+E2B4
—#↓—	U+F5E7	accidentalSharpJohnstonDown U+E262 U+E2B5
—b—	U+F5E8	accidentalFlatJohnstonEI U+E260 U+E2B2
—b↑—	U+F5E9	accidentalFlatJohnstonUp U+E260 U+E2B4
—b↓—	U+F5EA	accidentalFlatJohnstonDown U+E260 U+E2B5
—#—	U+F5EB	accidentalJohnstonSevenSharp U+E2B3 U+E262
—b—	U+F5EC	accidentalJohnstonSevenFlat U+E2B3 U+E260
—↑—	U+F5ED	accidentalJohnstonSevenUp U+E2B3 U+E2B4
—↓—	U+F5EE	accidentalJohnstonSevenDown U+E2B3 U+E2B5
—↑—	U+F5EF	accidentalJohnstonUpEI U+E2B4 U+E2B2
—↓—	U+F5F0	accidentalJohnstonDownEI U+E2B5 U+E2B2

























## Johnston accidentals (just intonation)

	U+F5F1	accidentalSharpJohnstonUpEI U+E262 U+E2B4 U+E2B2
	U+F5F2	accidentalSharpJohnstonDownEI U+E262 U+E2B5 U+E2B2
	U+F5F3	accidentalJohnstonSevenSharpUp U+E2B3 U+E262 U+E2B4
	U+F5F4	accidentalJohnstonSevenSharpDown U+E2B3 U+E262 U+E2B5
	U+F5F5	accidentalFlatJohnstonUpEI U+E260 U+E2B4 U+E2B2
	U+F5F6	accidentalFlatJohnstonEIDown U+E260 U+E2B2 U+E2B5
	U+F5F7	accidentalJohnstonSevenFlatUp U+E2B3 U+E260 U+E2B4
	U+F5F8	accidentalJohnstonSevenFlatDown U+E2B3 U+E260 U+E2B5

























## Extended Helmholtz-Ellis accidentals (just intonation)

	U+E2C0	accidentalDoubleFlatOneArrowDown
	U+E2C1	accidentalFlatOneArrowDown
	U+E2C2	accidentalNaturalOneArrowDown
	U+E2C3	accidentalSharpOneArrowDown
	U+E2C4	accidentalDoubleSharpOneArrowDown
	U+E2C5	accidentalDoubleFlatOneArrowUp
	U+E2C6	accidentalFlatOneArrowUp
	U+E2C7	accidentalNaturalOneArrowUp
	U+E2C8	accidentalSharpOneArrowUp
	U+E2C9	accidentalDoubleSharpOneArrowUp
	U+E2CA	accidentalDoubleFlatTwoArrowsDown
	U+E2CB	accidentalFlatTwoArrowsDown
	U+E2CC	accidentalNaturalTwoArrowsDown
	U+E2CD	accidentalSharpTwoArrowsDown
	U+E2CE	accidentalDoubleSharpTwoArrowsDown
	U+E2CF	accidentalDoubleFlatTwoArrowsUp
	U+E2D0	accidentalFlatTwoArrowsUp
	U+E2D1	accidentalNaturalTwoArrowsUp
	U+E2D2	accidentalSharpTwoArrowsUp
	U+E2D3	accidentalDoubleSharpTwoArrowsUp
	U+E2D4	accidentalDoubleFlatThreeArrowsDown
	U+E2D5	accidentalFlatThreeArrowsDown
	U+E2D6	accidentalNaturalThreeArrowsDown
	U+E2D7	accidentalSharpThreeArrowsDown
	U+E2D8	accidentalDoubleSharpThreeArrowsDown

## Extended Helmholtz-Ellis accidentals (just intonation)

	U+E2D9	accidentalDoubleFlatThreeArrowsUp
	U+E2DA	accidentalFlatThreeArrowsUp
	U+E2DB	accidentalNaturalThreeArrowsUp
	U+E2DC	accidentalSharpThreeArrowsUp
	U+E2DD	accidentalDoubleSharpThreeArrowsUp
	U+E2DE	accidentalLowerOneSeptimalComma
	U+E2DF	accidentalRaiseOneSeptimalComma
	U+E2E0	accidentalLowerTwoSeptimalCommas
	U+E2E1	accidentalRaiseTwoSeptimalCommas
	U+E2E2	accidentalLowerOneUndecimalQuartertone
	U+E2E3	accidentalRaiseOneUndecimalQuartertone
	U+E2E4	accidentalLowerOneTridecimalQuartertone
	U+E2E5	accidentalRaiseOneTridecimalQuartertone
	U+E2E6	accidentalCombiningLower17Schisma
	U+E2E7	accidentalCombiningRaise17Schisma
	U+E2E8	accidentalCombiningLower19Schisma
	U+E2E9	accidentalCombiningRaise19Schisma
	U+E2EA	accidentalCombiningLower23Limit29LimitComma
	U+E2EB	accidentalCombiningRaise23Limit29LimitComma
	U+EE50	accidentalCombiningLower29LimitComma
	U+EE51	accidentalCombiningRaise29LimitComma
	U+E2EC	accidentalCombiningLower31Schisma
	U+E2ED	accidentalCombiningRaise31Schisma
	U+EE52	accidentalCombiningLower37Quartertone
	U+EE53	accidentalCombiningRaise37Quartertone

## Extended Helmholtz-Ellis accidentals (just intonation)

	U+EE54	accidentalCombiningLower41Comma
	U+EE55	accidentalCombiningRaise41Comma
	U+EE56	accidentalCombiningLower43Comma
	U+EE57	accidentalCombiningRaise43Comma
	U+EE58	accidentalCombiningLower47Quartertone
	U+EE59	accidentalCombiningRaise47Quartertone
	U+E2F7	accidentalCombiningLower53LimitComma
	U+E2F8	accidentalCombiningRaise53LimitComma
	U+E2EE	accidentalCombiningOpenCurlyBrace
	U+E2EF	accidentalCombiningCloseCurlyBrace
	U+E2F0	accidentalDoubleFlatEqualTempered
	U+E2F1	accidentalFlatEqualTempered
	U+E2F2	accidentalNaturalEqualTempered
	U+E2F3	accidentalSharpEqualTempered
	U+E2F4	accidentalDoubleSharpEqualTempered
	U+E2F5	accidentalQuarterFlatEqualTempered
	U+E2F6	accidentalQuarterSharpEqualTempered
	U+F620	accidentalQuarterFlatFilledEqualTempered
	U+F621	accidentalThreeQuarterFlatEqualTempered
	U+F622	accidentalThreeQuarterFlatFilledEqualTempered
	U+F623	accidentalThreeQuarterSharpEqualTempered
	U+E2F9	accidentalEnharmonicTilde
	U+E2FA	accidentalEnharmonicAlmostEqualTo
	U+E2FB	accidentalEnharmonicEquals

## Arel-Ezgi-Uzdilek (AEU) accidentals

𐞀	U+E440	accidentalBuyukMucennebFlat
𐞁	U+E441	accidentalKucukMucennebFlat
𐞂	U+E442	accidentalBakiyeFlat
𐞃	U+E443	accidentalKomaFlat
𐞄	U+E444	accidentalKomaSharp
𐞅	U+E445	accidentalBakiyeSharp
𐞆	U+E446	accidentalKucukMucennebSharp
𐞇	U+E447	accidentalBuyukMucennebSharp









## Turkish folk music accidentals

♯ <sup>1</sup>	U+E450	accidental1CommaSharp
♯ <sup>2</sup>	U+E451	accidental2CommaSharp
♯ <sup>3</sup>	U+E452	accidental3CommaSharp
♯ <sup>5</sup>	U+E453	accidental5CommaSharp
♭ <sup>1</sup>	U+E454	accidental1CommaFlat
♭ <sup>2</sup>	U+E455	accidental2CommaFlat
♭ <sup>3</sup>	U+E456	accidental3CommaFlat
♭ <sup>4</sup>	U+E457	accidental4CommaFlat

## Persian accidentals







Ɱ	U+E460	accidentalKoron		24
Ɱ̄	U+F674	accidentalFlatKoron		
Ɱ̇	U+E461	accidentalSori		24
Ɱ̇̄	U+F676	accidentalSoriLarge	U+E461 salt	
Ɱ̇̇	U+F675	accidentalSoriSharp		
Ɱ̇̇̄	U+F677	accidentalSoriSharpLarge	U+F675 salt	

## Arabic accidentals

	U+ED30	accidentalDoubleFlatArabic	24
	U+ED31	accidentalThreeQuarterTonesFlatArabic	24
	U+ED32	accidentalFlatArabic	24
	U+ED33	accidentalQuarterToneFlatArabic	24
	U+ED34	accidentalNaturalArabic	24
	U+ED35	accidentalQuarterToneSharpArabic	24
	U+ED36	accidentalSharpArabic	24
	U+ED37	accidentalThreeQuarterTonesSharpArabic	24
	U+ED38	accidentalDoubleSharpArabic	24



## Medieval and Renaissance accidentals



























	U+E9E0	U+1D1D2	medRenFlatSoftB
	U+E9E1		medRenFlatHardB
	U+E9E2		medRenNatural
	U+E9E3	U+1D1CF	medRenSharpCroix
	U+E9E4		medRenFlatWithDot
	U+E9E5		medRenNaturalWithCross

## Sagittal Accidentals











## Spartan Sagittal single-shaft accidentals

↳	U+E300	accSagittal5v7KleismaUp	
↳	U+E301	accSagittal5v7KleismaDown	
↳	U+E302	accSagittal5CommaUp	72
↳	U+E303	accSagittal5CommaDown	72
↳	U+E304	accSagittal7CommaUp	72
↳	U+E305	accSagittal7CommaDown	72
↳	U+E306	accSagittal25SmallDiesisUp	
↳	U+E307	accSagittal25SmallDiesisDown	
↳	U+E308	accSagittal35MediumDiesisUp	
↳	U+E309	accSagittal35MediumDiesisDown	
↳	U+E30A	accSagittal11MediumDiesisUp	24 72
↳	U+E30B	accSagittal11MediumDiesisDown	24 72
↳	U+E30C	accSagittal11LargeDiesisUp	
↳	U+E30D	accSagittal11LargeDiesisDown	
↳	U+E30E	accSagittal35LargeDiesisUp	
↳	U+E30F	accSagittal35LargeDiesisDown	

## Spartan Sagittal multi-shaft accidentals

	U+E310	accSagittalSharp25SDown	
	U+E311	accSagittalFlat25SUp	
	U+E312	accSagittalSharp7CDown	72
	U+E313	accSagittalFlat7CUp	72
	U+E314	accSagittalSharp5CDown	72
	U+E315	accSagittalFlat5CUp	72
	U+E316	accSagittalSharp5v7kDown	
	U+E317	accSagittalFlat5v7kUp	
	U+E318	accSagittalSharp	12 24 72
	U+E319	accSagittalFlat	12 24 72
	U+E31C	accSagittalSharp5v7kUp	
	U+E31D	accSagittalFlat5v7kDown	
	U+E31E	accSagittalSharp5CUp	72
	U+E31F	accSagittalFlat5CDown	72
	U+E320	accSagittalSharp7CUp	72
	U+E321	accSagittalFlat7CDown	72
	U+E322	accSagittalSharp25SUp	
	U+E323	accSagittalFlat25SDown	
	U+E324	accSagittalSharp35MUp	
	U+E325	accSagittalFlat35MDown	
	U+E326	accSagittalSharp11MUp	24 72
	U+E327	accSagittalFlat11MDown	24 72
	U+E328	accSagittalSharp11LUp	
	U+E329	accSagittalFlat11LDown	
	U+E32A	accSagittalSharp35LUp	
	U+E32B	accSagittalFlat35LDown	











## Spartan Sagittal multi-shaft accidentals

	U+E32C	accSagittalDoubleSharp25SDown	
	U+E32D	accSagittalDoubleFlat25SUp	
	U+E32E	accSagittalDoubleSharp7CDown	72
	U+E32F	accSagittalDoubleFlat7CUp	72
	U+E330	accSagittalDoubleSharp5CDown	72
	U+E331	accSagittalDoubleFlat5CUp	72
	U+E332	accSagittalDoubleSharp5v7kDown	
	U+E333	accSagittalDoubleFlat5v7kUp	
	U+E334	accSagittalDoubleSharp	12 24 72
	U+E335	accSagittalDoubleFlat	12 24 72

























## Athenian Sagittal extension accidentals

	U+E340	accSagittal7v11KleismaUp
	U+E341	accSagittal7v11KleismaDown
	U+E342	accSagittal17CommaUp
	U+E343	accSagittal17CommaDown
	U+E344	accSagittal55CommaUp
	U+E345	accSagittal55CommaDown
	U+E346	accSagittal7v11CommaUp
	U+E347	accSagittal7v11CommaDown
	U+E348	accSagittal5v11SmallDiesisUp
	U+E349	accSagittal5v11SmallDiesisDown
	U+E34A	accSagittalSharp5v11SDown
	U+E34B	accSagittalFlat5v11SUp
	U+E34C	accSagittalSharp7v11CDown
	U+E34D	accSagittalFlat7v11CUp
	U+E34E	accSagittalSharp55CDown
	U+E34F	accSagittalFlat55CUp
	U+E350	accSagittalSharp17CDown
	U+E351	accSagittalFlat17CUp
	U+E352	accSagittalSharp7v11kDown
	U+E353	accSagittalFlat7v11kUp
	U+E354	accSagittalSharp7v11kUp
	U+E355	accSagittalFlat7v11kDown
	U+E356	accSagittalSharp17CUp
	U+E357	accSagittalFlat17CDown
	U+E358	accSagittalSharp55CUp
	U+E359	accSagittalFlat55CDown
	U+E35A	accSagittalSharp7v11CUp
	U+E35B	accSagittalFlat7v11CDown
	U+E35C	accSagittalSharp5v11SUp
	U+E35D	accSagittalFlat5v11SDown

## Athenian Sagittal extension accidentals

	U+E35E	accSagittalDoubleSharp5v11SDown
	U+E35F	accSagittalDoubleFlat5v11SUp
	U+E360	accSagittalDoubleSharp7v11CDown
	U+E361	accSagittalDoubleFlat7v11CUp
	U+E362	accSagittalDoubleSharp55CDown
	U+E363	accSagittalDoubleFlat55CUp
	U+E364	accSagittalDoubleSharp17CDown
	U+E365	accSagittalDoubleFlat17CUp
	U+E366	accSagittalDoubleSharp7v11kDown
	U+E367	accSagittalDoubleFlat7v11kUp

## Trojan Sagittal extension accidentals







	U+E370	accSagittal23CommaUp
	U+E371	accSagittal23CommaDown
	U+E372	accSagittal5v19CommaUp
	U+E373	accSagittal5v19CommaDown
	U+E374	accSagittal5v23SmallDiesisUp
	U+E375	accSagittal5v23SmallDiesisDown
	U+E376	accSagittalSharp5v23SDown
	U+E377	accSagittalFlat5v23SUp
	U+E378	accSagittalSharp5v19CDown
	U+E379	accSagittalFlat5v19CUp
	U+E37A	accSagittalSharp23CDown
	U+E37B	accSagittalFlat23CUp
	U+E37C	accSagittalSharp23CUp
	U+E37D	accSagittalFlat23CDown
	U+E37E	accSagittalSharp5v19CUp
	U+E37F	accSagittalFlat5v19CDown
	U+E380	accSagittalSharp5v23SUp
	U+E381	accSagittalFlat5v23SDown
	U+E382	accSagittalDoubleSharp5v23SDown
	U+E383	accSagittalDoubleFlat5v23SUp
	U+E384	accSagittalDoubleSharp5v19CDown
	U+E385	accSagittalDoubleFlat5v19CUp
	U+E386	accSagittalDoubleSharp23CDown
	U+E387	accSagittalDoubleFlat23CUp

## Promethean Sagittal extension single-shaft accidentals































	U+E390	accSagittal19SchismaUp
	U+E391	accSagittal19SchismaDown
	U+E392	accSagittal17KleismaUp
	U+E393	accSagittal17KleismaDown
	U+E394	accSagittal143CommaUp
	U+E395	accSagittal143CommaDown
	U+E396	accSagittal11v49CommaUp
	U+E397	accSagittal11v49CommaDown
	U+E398	accSagittal19CommaUp
	U+E399	accSagittal19CommaDown
	U+E39A	accSagittal7v19CommaUp
	U+E39B	accSagittal7v19CommaDown
	U+E39C	accSagittal49SmallDiesisUp
	U+E39D	accSagittal49SmallDiesisDown
	U+E39E	accSagittal23SmallDiesisUp
	U+E39F	accSagittal23SmallDiesisDown
	U+E3A0	accSagittal5v13MediumDiesisUp
	U+E3A1	accSagittal5v13MediumDiesisDown
	U+E3A2	accSagittal11v19MediumDiesisUp
	U+E3A3	accSagittal11v19MediumDiesisDown
	U+E3A4	accSagittal49MediumDiesisUp
	U+E3A5	accSagittal49MediumDiesisDown
	U+E3A6	accSagittal5v49MediumDiesisUp
	U+E3A7	accSagittal5v49MediumDiesisDown
	U+E3A8	accSagittal49LargeDiesisUp
	U+E3A9	accSagittal49LargeDiesisDown
	U+E3AA	accSagittal11v19LargeDiesisUp
	U+E3AB	accSagittal11v19LargeDiesisDown
	U+E3AC	accSagittal5v13LargeDiesisUp
	U+E3AD	accSagittal5v13LargeDiesisDown



















## Promethean Sagittal extension multi-shaft accidentals

	U+E3B0	accSagittalSharp23SDown
	U+E3B1	accSagittalFlat23SUp
	U+E3B2	accSagittalSharp49SDown
	U+E3B3	accSagittalFlat49SUp
	U+E3B4	accSagittalSharp7v19CDown
	U+E3B5	accSagittalFlat7v19CUp
	U+E3B6	accSagittalSharp19CDown
	U+E3B7	accSagittalFlat19CUp
	U+E3B8	accSagittalSharp11v49CDown
	U+E3B9	accSagittalFlat11v49CUp
	U+E3BA	accSagittalSharp143CDown
	U+E3BB	accSagittalFlat143CUp
	U+E3BC	accSagittalSharp17kDown
	U+E3BD	accSagittalFlat17kUp
	U+E3BE	accSagittalSharp19sDown
	U+E3BF	accSagittalFlat19sUp

## Promethean Sagittal extension multi-shaft accidentals

	U+E3C0	accSagittalSharp19sUp
	U+E3C1	accSagittalFlat19sDown
	U+E3C2	accSagittalSharp17kUp
	U+E3C3	accSagittalFlat17kDown
	U+E3C4	accSagittalSharp143CUp
	U+E3C5	accSagittalFlat143CDown
	U+E3C6	accSagittalSharp11v49CUp
	U+E3C7	accSagittalFlat11v49CDown
	U+E3C8	accSagittalSharp19CUp
	U+E3C9	accSagittalFlat19CDown
	U+E3CA	accSagittalSharp7v19CUp
	U+E3CB	accSagittalFlat7v19CDown
	U+E3CC	accSagittalSharp49SUp
	U+E3CD	accSagittalFlat49SDown
	U+E3CE	accSagittalSharp23SUp
	U+E3CF	accSagittalFlat23SDown
	U+E3D0	accSagittalSharp5v13MUp
	U+E3D1	accSagittalFlat5v13MDown
	U+E3D2	accSagittalSharp11v19MUp
	U+E3D3	accSagittalFlat11v19MDown
	U+E3D4	accSagittalSharp49MUp
	U+E3D5	accSagittalFlat49MDown
	U+E3D6	accSagittalSharp5v49MUp
	U+E3D7	accSagittalFlat5v49MDown
	U+E3D8	accSagittalSharp49LUp
	U+E3D9	accSagittalFlat49LDown
	U+E3DA	accSagittalSharp11v19LUp
	U+E3DB	accSagittalFlat11v19LDown
	U+E3DC	accSagittalSharp5v13LUp
	U+E3DD	accSagittalFlat5v13LDown

## Promethean Sagittal extension multi-shaft accidentals

	U+E3E0	accSagittalDoubleSharp23SDown
	U+E3E1	accSagittalDoubleFlat23SUp
	U+E3E2	accSagittalDoubleSharp49SDown
	U+E3E3	accSagittalDoubleFlat49SUp
	U+E3E4	accSagittalDoubleSharp7v19CDown
	U+E3E5	accSagittalDoubleFlat7v19CUp
	U+E3E6	accSagittalDoubleSharp19CDown
	U+E3E7	accSagittalDoubleFlat19CUp
	U+E3E8	accSagittalDoubleSharp11v49CDown
	U+E3E9	accSagittalDoubleFlat11v49CUp
	U+E3EA	accSagittalDoubleSharp143CDown
	U+E3EB	accSagittalDoubleFlat143CUp
	U+E3EC	accSagittalDoubleSharp17kDown
	U+E3ED	accSagittalDoubleFlat17kUp
	U+E3EE	accSagittalDoubleSharp19sDown
	U+E3EF	accSagittalDoubleFlat19sUp

## Herculean Sagittal extension accidental diacritics

— —	U+E3F0	accSagittalShaftUp
— —	U+E3F1	accSagittalShaftDown
—/—	U+E3F2	accSagittalAcute
—\—	U+E3F3	accSagittalGrave



























## Olympian Sagittal extension accidental diacritics

— <sup>^</sup> —	U+E3F4	accSagittal1MinaUp
— <sup>v</sup> —	U+E3F5	accSagittal1MinaDown
— <sup>m</sup> —	U+E3F6	accSagittal2MinasUp
— <sup>w</sup> —	U+E3F7	accSagittal2MinasDown

## Magrathean Sagittal extension accidental diacritics

— ˘	U+E3F8	accSagittal1TinaUp
— ˘̣	U+E3F9	accSagittal1TinaDown
— ˆ	U+E3FA	accSagittal2TinasUp
— ˆ̣	U+E3FB	accSagittal2TinasDown
— ˆ̣̣	U+E3FC	accSagittal3TinasUp
— ˆ̣̣̣	U+E3FD	accSagittal3TinasDown
— ˆ̣̣̣̣	U+E3FE	accSagittal4TinasUp
— ˆ̣̣̣̣̣	U+E3FF	accSagittal4TinasDown
— ˆ̣̣̣̣̣̣	U+E400	accSagittal5TinasUp
— ˆ̣̣̣̣̣̣̣	U+E401	accSagittal5TinasDown
— ˆ̣̣̣̣̣̣̣̣	U+E402	accSagittal6TinasUp
— ˆ̣̣̣̣̣̣̣̣̣	U+E403	accSagittal6TinasDown
— ˆ̣̣̣̣̣̣̣̣̣̣	U+E404	accSagittal7TinasUp
— ˆ̣̣̣̣̣̣̣̣̣̣̣	U+E405	accSagittal7TinasDown
— ˆ̣̣̣̣̣̣̣̣̣̣̣̣	U+E406	accSagittal8TinasUp
— ˆ̣̣̣̣̣̣̣̣̣̣̣̣̣	U+E407	accSagittal8TinasDown
— ˆ̣̣̣̣̣̣̣̣̣̣̣̣̣̣	U+E408	accSagittal9TinasUp
— ˆ̣̣̣̣̣̣̣̣̣̣̣̣̣̣̣	U+E409	accSagittal9TinasDown
— ˙	U+E40A	accSagittalFractionalTinaUp
— ˙̣	U+E40B	accSagittalFractionalTinaDown

## Other accidentals

	U+E470		accidentalXenakisOneThirdToneSharp	
	U+E471		accidentalXenakisTwoThirdTonesSharp	
	U+E472		accidentalQuarterToneSharpBusotti	
	U+E473		accidentalSharpOneHorizontalStroke	
	U+E474		accidentalThreeQuarterTonesSharpBusotti	
	U+E475		accidentalQuarterToneSharpWiggle	
	U+E476		accidentalTavenerSharp	
	U+E477		accidentalTavenerFlat	
	U+E478		accidentalQuarterToneFlatPenderecki	
	U+E479		accidentalCommaSlashUp	72
	U+E47A		accidentalCommaSlashDown	72
	U+E47B		accidentalWilsonPlus	72
	U+E47C		accidentalWilsonMinus	72
	U+E47D		accidentalLargeDoubleSharp	12 24 72
	U+E47E	U+1D132	accidentalQuarterToneSharp4	24
	U+E47F	U+1D133	accidentalQuarterToneFlat4	24
	U+E480		accidentalQuarterToneFlatFilledReversed	
	U+E481		accidentalSharpReversed	
	U+E482		accidentalNaturalReversed	
	U+E483		accidentalDoubleFlatReversed	
	U+E484		accidentalFlatTurned	
	U+E485		accidentalDoubleFlatTurned	
	U+E486		accidentalThreeQuarterTonesFlatGrisey	
	U+E487		accidentalThreeQuarterTonesFlatTartini	24
	U+E488		accidentalQuarterToneFlatVanBlankenburg	24
	U+E489		accidentalThreeQuarterTonesFlatCouper	24

## Other accidentals

↖	U+EE60	accidentalUpsAndDownsUp
↘	U+EE61	accidentalUpsAndDownsDown
↗	U+EE62	accidentalUpsAndDownsMore
↙	U+EE63	accidentalUpsAndDownsLess
⤵	U+F610	accidentalRingArrowDown
⤴	U+F611	accidentalRingArrowUp
♭	U+F612	accidentalHalfFlat
𝄫	U+F613	accidentalHalfDoubleFlat
♮	U+F619	accidentalReversedFlatSlash
𝄌	U+F61A	accidentalNarrowReversedFlatSlash
𝄍	U+F61B	accidentalDoubleFlatSlash



## Articulations

---

>	U+E4A0	U+1D17B	articAccentAbove	
>	U+E4A1		articAccentBelow	
>	U+F42A		articAccentAboveLarge	U+E4A0 salt 1
>	U+F42B		articAccentBelowLarge	U+E4A1 salt 1
▷	U+F532		articAccentAboveRossini	U+E4A0 salt 2
▷	U+F533		articAccentBelowRossini	U+E4A1 salt 2
·>	U+E4B0	U+1D181	articAccentStaccatoAbove U+E4A0 U+E4A2	
·>	U+E4B1		articAccentStaccatoBelow U+E4A1 U+E4A3	
≧	U+E4B4		articTenutoAccentAbove U+E4A0 U+E4A4	
≧	U+E4B5		articTenutoAccentBelow U+E4A1 U+E4A5	
≡	U+F694		articDoubleAccentAbove U+E4A0 U+E4A0	
≡	U+F695		articDoubleAccentBelow U+E4A1 U+E4A1	
≡	U+F696		articTripleAccentAbove U+E4A0 U+E4A0 U+E4A0	
≡	U+F697		articTripleAccentBelow U+E4A1 U+E4A1 U+E4A1	
≡	U+F698		articTenutoDoubleAccentAbove U+E4A4 U+E4A0 U+E4A0	
≡	U+F699		articTenutoDoubleAccentBelow U+E4A5 U+E4A1 U+E4A1	
-	U+E4A4	U+1D17D	articTenutoAbove	
-	U+E4A5		articTenutoBelow	
·-	U+E4B2	U+1D182	articTenutoStaccatoAbove U+E4A4 U+E4A2	
·-	U+E4B3		articTenutoStaccatoBelow U+E4A5 U+E4A3	





















## Articulations

.	U+E4A2	U+1D17C	articStaccatoAbove
.	U+E4A3		articStaccatoBelow
˙	U+E4A6	U+1D17E	articStaccatissimoAbove
˘	U+E4A7		articStaccatissimoBelow
˙	U+E4A8		articStaccatissimoWedgeAbove
˘	U+E4A9		articStaccatissimoWedgeBelow
˙	U+E4AA		articStaccatissimoStrokeAbove
˘	U+E4AB		articStaccatissimoStrokeBelow
:	U+F68E		articStaccatissimoColonAbove
:	U+F68F		articStaccatissimoColonBelow
ˆ	U+E4AC	U+1D17F	articMarcatoAbove
˘	U+E4AD		articMarcatoBelow
ˆ	U+E4AE	U+1D180	articMarcatoStaccatoAbove U+E4AC U+E4A2
˘	U+E4AF		articMarcatoStaccatoBelow U+E4AD U+E4A3
ˆ	U+F690		articMarcatoStaccatissimoAbove U+E4AC U+E4A6
˘	U+F691		articMarcatoStaccatissimoBelow U+E4AD U+E4A7
ˆ	U+E4BC		articMarcatoTenutoAbove U+E4AC U+E4A4
˘	U+E4BD		articMarcatoTenutoBelow U+E4AD U+E4A5
ˆ	U+F68C		articTenutoMarcatoAbove U+E4A4 U+E4AC
˘	U+F68D		articTenutoMarcatoBelow U+E4A5 U+E4AD
ˆ	U+F692		articMarcatoTenutoStaccatoAbove U+E4AC U+E4A4 U+E4A2
˘	U+F693		articMarcatoTenutoStaccatoBelow U+E4AD U+E4A5 U+E4A3























## Articulations

⤴	U+F69A	articDoubleMarcatoAbove U+E4AC U+E4AC	
⤵	U+F69B	articDoubleMarcatoBelow U+E4AD U+E4AD	
⤴⤴	U+F69C	articTripleMarcatoAbove U+E4AC U+E4AC U+E4AC	
⤵⤵	U+F69D	articTripleMarcatoBelow U+E4AD U+E4AD U+E4AD	
ˈ	U+E4B6	articStressAbove	
ˋ	U+E4B7	articStressBelow	
˘	U+E4B8	articUnstressAbove	
˙	U+E4B9	articUnstressBelow	
ˆ	U+E4BA	articLaissezVibrerAbove	
˜	U+E4BB	articLaissezVibrerBelow	
ˆˆ	U+F6FC	articLaissezVibrerAboveLong	U+E4BA salt 1
˜˜	U+F6FD	articLaissezVibrerBelowLong	U+E4BB salt 1
ˆˆˆ	U+F6FE	articLaissezVibrerAboveExtraLong	U+E4BA salt 2
˜˜˜	U+F6FF	articLaissezVibrerBelowExtraLong	U+E4BB salt 2
◁	U+ED40	articSoftAccentAbove	
▷	U+ED41	articSoftAccentBelow	
◁◦	U+ED42	articSoftAccentStaccatoAbove	
◦▷	U+ED43	articSoftAccentStaccatoBelow	
◁⇌	U+ED44	articSoftAccentTenutoAbove	
⇌▷	U+ED45	articSoftAccentTenutoBelow	
◁◦⇌	U+ED46	articSoftAccentTenutoStaccatoAbove	
⇌◦▷	U+ED47	articSoftAccentTenutoStaccatoBelow	

## Tremolos





























	U+E220	U+1D167	tremolo1
	U+E221	U+1D168	tremolo2
	U+E222	U+1D169	tremolo3
	U+E223		tremolo4
	U+E224		tremolo5
	U+E225	U+1D16A	tremoloFingered1
	U+E226	U+1D16B	tremoloFingered2
	U+E227	U+1D16C	tremoloFingered3
	U+E228		tremoloFingered4
	U+E229		tremoloFingered5
	U+E22A		buzzRoll
	U+E22B		pendereckiTremolo
	U+E22C		unmeasuredTremolo
	U+E22D		unmeasuredTremoloSimple
	U+E22E		tremoloDivisiDots2
	U+E22F		tremoloDivisiDots3
	U+E230		tremoloDivisiDots4
	U+E231		tremoloDivisiDots6
	U+E232		stockhausenTremolo
	U+E233		oneHandedRollStevens
	U+E234		doubleLateralRollStevens

## Rests

	U+E4E0		restMaxima	
	U+E4E1		restLonga	
	U+E4E2	U+1D13A	restDoubleWhole	
	U+E4E3	U+1D13B	restWhole	12 24 72
	U+E4E4	U+1D13C	restHalf	12 24 72
	U+E4E5	U+1D13D	restQuarter	12 24 72
	U+E4E6	U+1D13E	rest8th	12 24 72
	U+E4E7	U+1D13F	rest16th	12 24 72
	U+E4E8	U+1D140	rest32nd	12 24 72
	U+E4E9	U+1D141	rest64th	12 24 72
	U+E4EA	U+1D142	rest128th	
	U+E4EB		rest256th	
	U+E4EC		rest512th	
	U+E4ED		rest1024th	
	U+E4F2		restQuarterOld	
	U+E4F6		restQuarterZ	
	U+E4F3		restDoubleWholeLegerLine	
	U+E4F4		restWholeLegerLine	
	U+E4F5		restHalfLegerLine	
	U+E4EE	U+1D129	restHBar	
	U+E4EF		restHBarLeft	
	U+E4F0		restHBarMiddle	
	U+E4F1		restHBarRight	

## Holds and Pauses

















---

	U+E4C0	U+1D110	fermataAbove
	U+E4C1	U+1D111	fermataBelow
	U+E4C4		fermataShortAbove
	U+E4C5		fermataShortBelow
	U+E4C2		fermataVeryShortAbove
	U+E4C3		fermataVeryShortBelow
	U+F69E		fermataExtraShortAbove
	U+F69F		fermataExtraShortBelow
	U+E4C6		fermataLongAbove
	U+E4C7		fermataLongBelow
	U+E4C8		fermataVeryLongAbove
	U+E4C9		fermataVeryLongBelow
	U+F6A0		fermataExtraLongAbove
	U+F6A1		fermataExtraLongBelow
	U+E4CA		fermataLongHenzeAbove
	U+E4CB		fermataLongHenzeBelow
	U+E4CC		fermataShortHenzeAbove
	U+E4CD		fermataShortHenzeBelow
	U+E4CE	U+1D112	breathMarkComma
	U+F63F		breathMarkCommaTurned
	U+F640		breathMarkCommaWedge
	U+F641		breathMarkCommaWedgeTurned
	U+F6A2		breathMarkCommaShort
	U+F6A3		breathMarkCommaVeryShort
	U+E4CF		breathMarkTick
	U+E4D0		breathMarkUpbow
	U+E4D5		breathMarkSalzedo
	U+E4D6		curlwSign

## Holds and Pauses







//	U+E4D1	U+1D113	caesura	
/	U+F42C		caesuraSlashSingleStroke	U+E4D1 salt
//	U+E4D2		caesuraThick	
	U+E4D3		caesuraShort	
	U+E4D7		caesuraSingleStroke	
//	U+E4D4		caesuraCurved	

## Repeats and Bar repeats

	U+E040	U+1D106	repeatLeft	
	U+E041	U+1D107	repeatRight	
	U+E042		repeatRightLeft	
	U+F45C		repeatRightLeftThick	U+E042 salt
	U+E04C		leftRepeatSmall	
	U+E04D		rightRepeatSmall	
⋮	U+E043	U+1D108	repeatDots	
⋅	U+E044		repeatDot	
D.S.	U+E045	U+1D109	dalSegno	
D.C.	U+E046	U+1D10A	daCapo	
	U+E047	U+1D10B	segno	
	U+F404		segnoJapanese	U+E047 salt
	U+E048	U+1D10C	coda	
	U+E049		codaSquare	
	U+F405		codaJapanese	U+E048 salt
	U+E04A		segnoSerpent1	
	U+E04B		segnoSerpent2	
	U+F6C8		segnoSerpentSmall1	U+E04A salt 1
	U+F6C9		segnoSerpentSmall2	U+E04B salt 1
	U+F6CA		segnoSerpentLarge1	U+E04A salt 2
	U+F6CB		segnoSerpentLarge2	U+E04B salt 2



## Bar repeats

	U+E500	U+1D10E	repeat1Bar
	U+E501	U+1D10F	repeat2Bars
	U+E502		repeat4Bars
	U+E503		repeatBarUpperDot
	U+E504		repeatBarSlash
	U+E505		repeatBarLowerDot

























## Dynamics

<i>p</i>	U+E520	U+1D18F	dynamicPiano
<i>pp</i>	U+E52B		dynamicPP
<i>ppp</i>	U+E52A		dynamicPPP
<i>pppp</i>	U+E529		dynamicPPPP
<i>ppppp</i>	U+E528		dynamicPPPPP
<i>pppppp</i>	U+E527		dynamicPPPPPP
<i>m</i>	U+E521	U+1D190	dynamicMezzo
<i>mp</i>	U+E52C		dynamicMP
<i>mf</i>	U+E52D		dynamicMF
<i>f</i>	U+E522	U+1D191	dynamicForte
<i>ff</i>	U+E52F		dynamicFF
<i>fff</i>	U+E530		dynamicFFF
<i>ffff</i>	U+E531		dynamicFFFF
<i>fffff</i>	U+E532		dynamicFFFFFF
<i>ffffff</i>	U+E533		dynamicFFFFFFF
<i>pf</i>	U+E52E		dynamicPF
<i>fp</i>	U+E534		dynamicFortePiano
<i>z</i>	U+E525	U+1D18E	dynamicZ
<i>fz</i>	U+E535		dynamicForzando
<i>s</i>	U+E524	U+1D18D	dynamicSforzando
<i>sf</i>	U+E536		dynamicSforzando1
<i>sfp</i>	U+E537		dynamicSforzandoPiano
<i>sfpf</i>	U+E538		dynamicSforzandoPianissimo
<i>sfz</i>	U+F645		dynamicSforzandoFF
<i>sp</i>	U+F646		dynamicSP
<i>spp</i>	U+F647		dynamicSPP
<i>sfz</i>	U+E539		dynamicSforzato
<i>sfzp</i>	U+E53A		dynamicSforzatoPiano
<i>sfzff</i>	U+E53B		dynamicSforzatoFF
<i>sfzfff</i>	U+F6F4		dynamicSforzatoFFF
<i>sfzffff</i>	U+F6F5		dynamicSforzatoFFFF

## Dynamics

<i>r</i>	U+E523	U+1D18C	dynamicRinforzando	
<i>rf</i>	U+E53C		dynamicRinforzando1	
<i>rfz</i>	U+E53D		dynamicRinforzando2	
<i>n</i>	U+E526		dynamicNiente	
◁	U+E53E	U+1D192	dynamicCrescendoHairpin	
▷	U+E53F	U+1D193	dynamicDiminuendoHairpin	
◁▷	U+E540		dynamicMessaDiVoce	
∩	U+F63B		dynamicCrescendoJazz	
◦	U+E541		dynamicNienteForHairpin	
∕	U+F63A		dynamicNienteSlashedForHairpin	U+E541 salt
(	U+E542		dynamicHairpinParenthesisLeft	
)	U+E543		dynamicHairpinParenthesisRight	
[	U+E544		dynamicHairpinBracketLeft	
]	U+E545		dynamicHairpinBracketRight	
:	U+E546		dynamicCombinedSeparatorColon	
-	U+E547		dynamicCombinedSeparatorHyphen	
□	U+E548		dynamicCombinedSeparatorSpace	
/	U+E549		dynamicCombinedSeparatorSlash	

## Ornaments

	U+E560	U+1D194	graceNoteAcciaccaturaStemUp	
	U+E561		graceNoteAcciaccaturaStemDown	
	U+E562	U+1D195	graceNoteAppoggiaturaStemUp	
	U+E563		graceNoteAppoggiaturaStemDown	
	U+F656		graceNoteStemUp	
	U+F657		graceNoteStemDown	
	U+E564		graceNoteSlashStemUp	
	U+E565		graceNoteSlashStemDown	
	U+E566	U+1D196	ornamentTrill	
	U+F5BD		ornamentTrillFlatAbove U+E260 U+E566	
	U+F5BE		ornamentTrillNaturalAbove U+E261 U+E566	
	U+F5BF		ornamentTrillSharpAbove U+E262 U+E566	
	U+F6B9		ornamentTrillSimple	U+E566 salt
	U+E56C		ornamentShortTrill	
	U+E56D		ornamentMordent	
	U+E56E		ornamentTremblement	
	U+E567	U+1D197	ornamentTurn	
	U+E568	U+1D198	ornamentTurnInverted	
	U+E569	U+1D199	ornamentTurnSlash	
	U+E56A	U+1D19A	ornamentTurnUp	
	U+E56B		ornamentTurnUpS	
	U+E56F		ornamentHaydn	
	U+F5C0		ornamentTurnFlatAbove U+E260 U+E567	
	U+F5C1		ornamentTurnFlatAboveSharpBelow U+E260 U+E567 U+E262	
	U+F5C2		ornamentTurnFlatBelow U+E567 U+E260	

## Ornaments



U+F5C3

ornamentTurnNaturalAbove  
U+E261 U+E567

U+F5C4

ornamentTurnNaturalBelow  
U+E567 U+E261

U+F5C5

ornamentTurnSharpAbove  
U+E262 U+E567

U+F5C6

ornamentTurnSharpAboveFlatBelow  
U+E262 U+E567 U+E260

























U+F5C7

ornamentTurnSharpBelow  
U+E567 U+E262

## Combining strokes for trills and mordents

↘	U+E590		ornamentTopLeftConcaveStroke
↙	U+E591	U+1D1A5	ornamentTopLeftConvexStroke
↖	U+E592		ornamentHighLeftConcaveStroke
↗	U+E593	U+1D1A2	ornamentHighLeftConvexStroke
↓	U+E594	U+1D19B	ornamentLeftVerticalStroke
⊥	U+E595		ornamentLeftVerticalStrokeWithCross
⊕	U+E596		ornamentLeftShakeT
⊕	U+E597		ornamentLeftPlus
↙	U+E598		ornamentLowLeftConcaveStroke
↘	U+E599	U+1D1A4	ornamentLowLeftConvexStroke
↘	U+E59A		ornamentBottomLeftConcaveStroke
↙	U+E59B	U+1D1A1	ornamentBottomLeftConcaveStrokeLarge
↘	U+E59C		ornamentBottomLeftConvexStroke
↖	U+E59D	U+1D19C	ornamentZigZagLineNoRightEnd
↖	U+E59E	U+1D19D	ornamentZigZagLineWithRightEnd
	U+E59F	U+1D1A0	ornamentMiddleVerticalStroke
↗	U+E5A0		ornamentTopRightConcaveStroke
↖	U+E5A1	U+1D19E	ornamentTopRightConvexStroke
↗	U+E5A2		ornamentHighRightConcaveStroke
↖	U+E5A3		ornamentHighRightConvexStroke
)	U+E5A4		ornamentRightVerticalStroke
↘	U+E5A5	U+1D1A3	ornamentLowRightConcaveStroke
↗	U+E5A6		ornamentLowRightConvexStroke
↖	U+E5A7	U+1D19F	ornamentBottomRightConcaveStroke
↗	U+E5A8		ornamentBottomRightConvexStroke

## Precomposed trills and mordents

	U+E5B0	ornamentPrecompSlide
	U+E5B1	ornamentPrecompDescendingSlide
	U+E5B2	ornamentPrecompAppoggTrill
	U+E5B3	ornamentPrecompAppoggTrillSuffix
	U+E5B4	ornamentPrecompTurnTrillDAnglebert
	U+E5B5	ornamentPrecompSlideTrillDAnglebert
	U+E5B6	ornamentPrecompSlideTrillMarpurg
	U+E5B7	ornamentPrecompTurnTrillBach
	U+E5B8	ornamentPrecompSlideTrillBach
	U+E5B9	ornamentPrecompSlideTrillMuffat
	U+E5BA	ornamentPrecompSlideTrillSuffixMuffat
	U+E5BB	ornamentPrecompTrillSuffixDandrieu
	U+E5BC	ornamentPrecompPortDeVoixMordent
	U+E5BD	ornamentPrecompTrillWithMordent
	U+E5BE	ornamentPrecompCadence
	U+E5BF	ornamentPrecompCadenceWithTurn
	U+E5C0	ornamentPrecompDoubleCadenceLowerPrefix
	U+E5C1	ornamentPrecompCadenceUpperPrefix
	U+E5C2	ornamentPrecompCadenceUpperPrefixTurn
	U+E5C3	ornamentPrecompDoubleCadenceUpperPrefix
	U+E5C4	ornamentPrecompDoubleCadenceUpperPrefixTurn
	U+E5C5	ornamentPrecompMordentRelease
	U+E5C6	ornamentPrecompMordentUpperPrefix
	U+E5C7	ornamentPrecompInvertedMordentUpperPrefix
	U+E5C8	ornamentPrecompTrillLowerSuffix

## Multi-segment Lines

---



























~	U+EAA0	wiggleTrillFastest
~	U+EAA1	wiggleTrillFasterStill
~	U+EAA2	wiggleTrillFaster
~	U+EAA3	wiggleTrillFast
~	U+EAA4	wiggleTrill
~	U+EAA5	wiggleTrillSlow
~	U+EAA6	wiggleTrillSlower
~	U+EAA7	wiggleTrillSlowerStill
~	U+EAA8	wiggleTrillSlowest
~	U+EAA9	wiggleArpeggiatoUp
∨	U+EAAA	wiggleArpeggiatoDown
↘	U+EABB	wiggleArpeggiatoUpSwash
↙	U+EAAC	wiggleArpeggiatoDownSwash
↗	U+EAAD	wiggleArpeggiatoUpArrow
↖	U+EAAE	wiggleArpeggiatoDownArrow
~	U+EAAF	wiggleGlissando
⌘	U+EABD	wiggleGlissandoGroup1
⌘	U+EABE	wiggleGlissandoGroup2
⌘	U+EABF	wiggleGlissandoGroup3
~	U+EAB0	wiggleVibrato
~	U+EAB1	wiggleVibratoWide
~	U+EAB2	guitarVibratoStroke
~	U+EAB3	guitarWideVibratoStroke























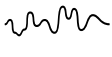







## Multi-segment Lines

u	U+EACC	wiggleVibratoStart
˘	U+EACD	wiggleVibratoSmallestFastest
˘	U+EACE	wiggleVibratoSmallestFasterStill
˘	U+EACF	wiggleVibratoSmallestFaster
˘	U+EAD0	wiggleVibratoSmallestFast
˘	U+EAD1	wiggleVibratoSmallestSlow
˘	U+EAD2	wiggleVibratoSmallestSlower
˘	U+EAD3	wiggleVibratoSmallestSlowest
˘	U+EAD4	wiggleVibratoSmallFastest
˘	U+EAD5	wiggleVibratoSmallFasterStill
˘	U+EAD6	wiggleVibratoSmallFaster
˘	U+EAD7	wiggleVibratoSmallFast
˘	U+EAD8	wiggleVibratoSmallSlow
˘	U+EAD9	wiggleVibratoSmallSlower
˘	U+EADA	wiggleVibratoSmallSlowest
˘	U+EADB	wiggleVibratoMediumFastest
˘	U+EADC	wiggleVibratoMediumFasterStill
˘	U+EADD	wiggleVibratoMediumFaster
˘	U+EADE	wiggleVibratoMediumFast
˘	U+EADF	wiggleVibratoMediumSlow
˘	U+EAE0	wiggleVibratoMediumSlower
˘	U+EAE1	wiggleVibratoMediumSlowest
˘	U+EAE2	wiggleVibratoLargeFastest
˘	U+EAE3	wiggleVibratoLargeFasterStill
˘	U+EAE4	wiggleVibratoLargeFaster
˘	U+EAE5	wiggleVibratoLargeFast
˘	U+EAE6	wiggleVibratoLargeSlow
˘	U+EAE7	wiggleVibratoLargeSlower
˘	U+EAE8	wiggleVibratoLargeSlowest

## Multi-segment Lines

	U+EAE9	wiggleVibratoLargestFastest
	U+EAEA	wiggleVibratoLargestFasterStill
	U+EAEB	wiggleVibratoLargestFaster
	U+EAEC	wiggleVibratoLargestFast
	U+EAED	wiggleVibratoLargestSlow
	U+EAEF	wiggleVibratoLargestSlower
	U+EAEF	wiggleVibratoLargestSlowest
	U+F6B3	wiggleWavyNarrower
	U+EAB4	wiggleWavyNarrow
	U+EAB5	wiggleWavy
	U+EAB6	wiggleWavyWide
	U+F6B4	wiggleWavyWider
	U+F6B5	wiggleSquareWaveNarrower
	U+EAB7	wiggleSquareWaveNarrow
	U+EAB8	wiggleSquareWave
	U+EAB9	wiggleSquareWaveWide
	U+F6B6	wiggleSquareWaveWider
	U+F6B7	wiggleSawtoothNarrower
	U+EABA	wiggleSawtoothNarrow
	U+EABB	wiggleSawtooth
	U+EABC	wiggleSawtoothWide
	U+F6B8	wiggleSawtoothWider
	U+EAC0	wiggleCircularConstant
	U+EAC1	wiggleCircularConstantFlipped
	U+EAC2	wiggleCircularConstantLarge
	U+EAC3	wiggleCircularConstantFlippedLarge

## Multi-segment Lines

	U+EAC4	wiggleCircularStart
	U+EAC5	wiggleCircularLargest
	U+EAC6	wiggleCircularLargerStill
	U+EAC7	wiggleCircularLarger
	U+EAC8	wiggleCircularLarge
	U+EAC9	wiggleCircular
	U+EACA	wiggleCircularSmall
	U+EACB	wiggleCircularEnd
	U+EAF0	wiggleRandom1
	U+EAF1	wiggleRandom2
	U+EAF2	wiggleRandom3
	U+EAF3	wiggleRandom4
	U+EAF4	beamAccelRit1
	U+EAF5	beamAccelRit2
	U+EAF6	beamAccelRit3
	U+EAF7	beamAccelRit4
	U+EAF8	beamAccelRit5
	U+EAF9	beamAccelRit6
	U+EAF A	beamAccelRit7
	U+EAF B	beamAccelRit8
	U+EAF C	beamAccelRit9
	U+EAF D	beamAccelRit10
	U+EAF E	beamAccelRit11
	U+EAF F	beamAccelRit12
	U+EB00	beamAccelRit13
	U+EB01	beamAccelRit14
	U+EB02	beamAccelRit15
	U+EB03	beamAccelRitFinal

Multi-segment Lines

Examples:

Trill with ornament



Trill with wind



Arpeggiato



Glissando



Vibrato / Shake



Vibrato variable



Wavy / Square / Sawtooth

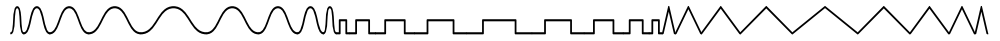

Constant circular motion

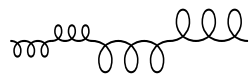

Circular motion



Random and others







Accel. / Rit. Beam























## Wind instruments

☺	U+E5F0		doubleTongueAbove	
☹	U+E5F1	U+1D18A	doubleTongueBelow	
..	U+F42D		doubleTongueAboveNoSlur	U+E5F0 salt
..	U+F42E		doubleTongueBelowNoSlur	U+E5F1 salt
☺☺☺	U+E5F2		tripleTongueAbove	
☹☹☹	U+E5F3	U+1D18B	tripleTongueBelow	
...	U+F42F		tripleTongueAboveNoSlur	U+E5F2 salt
...	U+F430		tripleTongueBelowNoSlur	U+E5F3 salt
●	U+E5F4		windClosedHole	
◐	U+E5F5		windThreeQuartersClosedHole	
◑	U+E5F6		windHalfClosedHole1	
◒	U+E5F7		windHalfClosedHole2	
◓	U+E5F8		windHalfClosedHole3	
○	U+E5F9		windOpenHole	
◑◑	U+F6A6		windClosedDoubleHole	
◑◓	U+F6A8		windClosedOpenDoubleHole	
◓◑	U+F6A7		windOpenClosedDoubleHole	
◓◓	U+F6A5		windOpenDoubleHole	
△	U+E5FB		windFlatEmbouchure	
▽	U+E5FC		windSharpEmbouchure	
○	U+E5FD		windRelaxedEmbouchure	
◉	U+E5FE		windLessRelaxedEmbouchure	
●	U+E5FF		windTightEmbouchure	
◐	U+E600		windLessTightEmbouchure	
◑	U+E601		windVeryTightEmbouchure	
□	U+E602		windWeakAirPressure	
■	U+E603		windStrongAirPressure	
🎷	U+E604		windReedPositionNormal	
🎷	U+E605		windReedPositionOut	
🎷	U+E606		windReedPositionIn	













## Wind instruments

	U+E607	windMultiphonicsBlackStem
	U+E608	windMultiphonicsWhiteStem
	U+E609	windMultiphonicsBlackWhiteStem
	U+E5FA	windTrillKey
	U+E60A	windMouthpiecePop
	U+E60B	windRimOnly
	U+1FA88	Flute
	U+1F3B7	Saxophone

Brass wind instruments

	U+E5D1		brassLiftShort
	U+E5D2		brassLiftMedium
	U+E5D3		brassLiftLong
	U+E5DD		brassFallRoughShort
	U+E5DE		brassFallRoughMedium
	U+E5DF		brassFallRoughLong
	U+E5EC		brassLiftSmoothShort
	U+E5ED		brassLiftSmoothMedium
	U+E5EE		brassLiftSmoothLong
	U+E5DA		brassFallSmoothShort
	U+E5DB		brassFallSmoothMedium
	U+E5DC		brassFallSmoothLong
	U+E5D0		brassScoop
	U+E5D4	U+1D185	brassDoitShort
	U+E5D5		brassDoitMedium
	U+E5D6		brassDoitLong
	U+E5E0		brassPlop
	U+E5D7	U+1D186	brassFallLipShort
	U+E5D8		brassFallLipMedium
	U+E5D9		brassFallLipLong

## Brass wind instruments









	U+E5E1	U+1D187	brassFlip
	U+E5E2	U+1D188	brassSmear
	U+E5E3	U+1D189	brassBend
	U+E5E4		brassJazzTurn
+	U+E5E5		brassMuteClosed
	U+E5E6		brassMuteHalfClosed
	U+E5E7		brassMuteOpen
	U+E5E8		brassHarmonMuteClosed
	U+E5E9		brassHarmonMuteStemHalfLeft
	U+E5EA		brassHarmonMuteStemHalfRight
	U+F6A4		brassHarmonMuteStemHalfCross
	U+E5EB		brassHarmonMuteStemOpen
	U+E5EF		brassValveTrill
		U+1F3BA	Trumpet



## String instruments

▢	U+E610	U+1D1AA	stringsDownBow	
└	U+E611		stringsDownBowTurned	
▣	U+E61B		stringsOverpressureDownBow	
▤	U+E61D		stringsOverpressurePossibileDownBow	
∨	U+E612	U+1D1AB	stringsUpBow	
∧	U+E613		stringsUpBowTurned	
∇	U+E61C		stringsOverpressureUpBow	
∘	U+E61E		stringsOverpressurePossibileUpBow	
▶	U+E61F		stringsOverpressureNoDirection	
(▢∨)	U+E626		stringsChangeBowDirection	
▢∨	U+F431		stringsChangeBowDirectionLiga	U+E626 salt 1
▢	U+F43E		stringsChangeBowDirectionImposed	U+E626 salt 2
○	U+E614	U+1D1AC	stringsHarmonic	
◐	U+E615		stringsHalfHarmonic	
◇	U+F658		stringsHarmonicDiamond	U+E614 salt
◦	U+F63C		stringsOpen	
∅	U+F63D		stringsHalfOpen	
ϕ	U+F63E		stringsHalfOpenVertical	
▢	U+E616		stringsMuteOn	
▣	U+E617		stringsMuteOff	
↶	U+E618		stringsBowBehindBridge	
↷	U+E627		stringsBowBehindBridgeOneString	
↸	U+E628		stringsBowBehindBridgeTwoStrings	
↹	U+E629		stringsBowBehindBridgeThreeStrings	
↺	U+E62A		stringsBowBehindBridgeFourStrings	
↻	U+E619		stringsBowOnBridge	
┴	U+E61A		stringsBowOnTailpiece	
☹	U+E620		stringsJeteAbove	
☺	U+E621		stringsJeteBelow	

## String instruments

	U+E622	stringsFouette
	U+E623	stringsVibratoPulse
	U+E624	stringsThumbPosition
	U+E625	stringsThumbPositionTurned
	U+F6A9	stringsArco
	U+F6AA	stringsColLegno
	U+F6AB	stringsColLegnoBattuto
	U+F6AC	stringsColLegnoTratto
	U+1F3BB	Violin



## Plucked techniques

∅	U+E630	U+1D1AD	pluckedSnapPizzicatoBelow	
⊖	U+E631		pluckedSnapPizzicatoAbove	
∅	U+F432		pluckedSnapPizzicatoBelowGerman	U+E630 salt
⊖	U+F433		pluckedSnapPizzicatoAboveGerman	U+E631 salt
⊖	U+E632		pluckedBuzzPizzicato	
+	U+E633		pluckedLeftHandPizzicato	
⊕	U+F6AD		pluckedLeftHandPizzicatoHarmonicAbove U+E614 U+E633	
⊕	U+F6AE		pluckedLeftHandPizzicatoHarmonicBelow U+E633 U+E614	
∩	U+E636	U+1D1B3	pluckedWithFingernails	
⊔	U+E637		pluckedFingernailFlick	
∩	U+E63A		pluckedPlectrum	
⊕	U+E638	U+1D1B4	pluckedDamp	
⊕	U+E639	U+1D1B5	pluckedDampAll	
⊕	U+E63B		pluckedDampOnStem	
⤴				
⤴	U+E634	U+1D183	arpeggiatoUp	
⤵				
⤵	U+E635	U+1D184	arpeggiatoDown	
⤴				
⤴	U+E63C		arpeggiato	









## Chop (percussive bowing) notation

▣	U+EE80	stringsDownBowTowardsBody
∨	U+EE81	stringsUpBowTowardsBody
⊠	U+EE82	stringsDownBowAwayFromBody
∨̄	U+EE83	stringsUpBowAwayFromBody
⊠̄	U+EE84	stringsDownBowBeyondBridge
∨̄̄	U+EE85	stringsUpBowBeyondBridge
↵	U+EE86	stringsScrapeParallelInward
↶	U+EE87	stringsScrapeParallelOutward
↻	U+EE88	stringsScrapeCircularClockwise
↺	U+EE89	stringsScrapeCircularCounterclockwise
↻̄	U+EE8A	stringsTripleChopInward
↺̄	U+EE8B	stringsTripleChopOutward





























## Guitar

✓	U+E830	guitarVibratoBarScoop
∨	U+E831	guitarVibratoBarDip
⚡	U+E832	guitarShake
①	U+E833	guitarString0
②	U+E834	guitarString1
③	U+E835	guitarString2
④	U+E836	guitarString3
⑤	U+E837	guitarString4
⑥	U+E838	guitarString5
⑦	U+E839	guitarString6
⑧	U+E83A	guitarString7
⑨	U+E83B	guitarString8
⑩	U+E83C	guitarString9
⑪	U+E84A	guitarString10
⑫	U+E84B	guitarString11
⑬	U+E84C	guitarString12
⑭	U+E84D	guitarString13
○	U+E83D	guitarOpenPedal
⊕	U+E83E	guitarHalfOpenPedal
+	U+E83F	guitarClosePedal
Ⓣ	U+E840	guitarLeftHandTapping
Ⓡ	U+E841	guitarRightHandTapping
*	U+E842	guitarGolpe
<	U+E843	guitarFadeln
>	U+E844	guitarFadeOut
◇	U+E845	guitarVolumeSwell
↑	U+E846	guitarStrumUp
↓	U+E847	guitarStrumDown
<b>C</b>	U+E848	guitarBarreFull
$\frac{1}{2}$ <b>C</b>	U+E849	guitarBarreHalf
	U+1F3B8	Guitar
	U+1FA95	Banjo





## Chord diagrams

	U+E850		fretboard3String
	U+E851		fretboard3StringNut
	U+E852	U+1D11D	fretboard4String
	U+E853		fretboard4StringNut
	U+E854		fretboard5String
	U+E855		fretboard5StringNut
	U+E856	U+1D11C	fretboard6String
	U+E857		fretboard6StringNut
•	U+E858		fretboardFilledCircle
x	U+E859		fretboardX
o	U+E85A		fretboardO

## Harp



















	U+E680	harpPedalRaised
	U+F648	harpPedalRaisedChange
	U+E681	harpPedalCentered
	U+F649	harpPedalCenteredChange
	U+E682	harpPedalLowered
	U+F64A	harpPedalLoweredChange
	U+E683	harpPedalDivider
	U+E684	harpSalzedoSlideWithSuppleness
	U+E685	harpSalzedoOboicFlux
	U+E686	harpSalzedoThunderEffect
	U+E687	harpSalzedoWhistlingSounds
	U+E688	harpSalzedoMetallicSounds
	U+E69B	harpSalzedoMetallicSoundsOneString
	U+E689	harpSalzedoTamTamSounds
	U+E68B	harpSalzedoTimpanicSounds
	U+E69D	harpSalzedoSnareDrum
	U+E69C	harpSalzedoIsolatedSounds
	U+E68A	harpSalzedoPlayUpperEnd
	U+E68D	harpSalzedoFluidicSoundsLeft
	U+E68E	harpSalzedoFluidicSoundsRight
	U+E695	harpSalzedoAeolianAscending
	U+E696	harpSalzedoAeolianDescending
	U+E68C	harpSalzedoMuffleTotally
	U+E697	harpSalzedoDampLowStrings
	U+E698	harpSalzedoDampBothHands
	U+E699	harpSalzedoDampBelow
	U+E69A	harpSalzedoDampAbove
	U+E694	harpStringNoiseStem

## Harp



	U+E68F	harpMetalRod
	U+E690	harpTuningKey
	U+E691	harpTuningKeyHandle
	U+E692	harpTuningKeyShank
	U+E693	harpTuningKeyGlissando



## Keyed instruments

	U+E650	U+1D1AE	keyboardPedalPed	
	U+F434		keyboardPedalPedNoDot	U+E650 salt
	U+E651		keyboardPedalP	
	U+F6AF		keyboardPedalPOld	U+E651 salt
<i>e</i>	U+E652		keyboardPedalE	
<i>ð</i>	U+E653		keyboardPedalD	
<b>Sost.</b>	U+E659		keyboardPedalSost	
<b>Sost</b>	U+F435		keyboardPedalSostNoDot	U+E659 salt
<b>Sos.</b>	U+F6D1		keyboardPedalSos2	
<i>sos.</i>	U+F6D0		keyboardPedalSos	
<b>S</b>	U+E65A		keyboardPedalS	
<i>una corda</i>	U+F6CC		keyboardPedalUnaCorda	
<i>tre corde</i>	U+F6CD		keyboardPedalTreCorde	
<i>u.c.</i>	U+F6CE		keyboardPedalUC	
<i>t.c.</i>	U+F6CF		keyboardPedalTC	
.	U+E654		keyboardPedalDot	
-	U+E658		keyboardPedalHyphen	
	U+E655	U+1D1AF	keyboardPedalUp	
	U+E65D		keyboardPedalUpSpecial	
	U+E65B		keyboardPedalHalf2	
	U+E65C		keyboardPedalHalf3	
$\frac{1}{2}$ 	U+F6B0		keyboardPedalHalf4	
	U+E656	U+1D1B0	keyboardPedalHalf	
	U+E657		keyboardPedalUpNotch	
	U+F6BA		keyboardPedalPosQuarter	
	U+F6BB		keyboardPedalPosHalf	
	U+F6BC		keyboardPedalPosThreeQuarters	
	U+F6BD		keyboardPedalPosFull	
	U+E65E		keyboardLeftPedalPictogram	
	U+E65F		keyboardMiddlePedalPictogram	
	U+E660		keyboardRightPedalPictogram	

















## Keyed instruments

U	U+E661	keyboardPedalHeel1	
∩	U+E662	keyboardPedalHeel2	
○	U+E663	keyboardPedalHeel3	
⌞	U+F6B1	keyboardPedalHeel1Old	U+E661 salt
⌟	U+F6B2	keyboardPedalHeel2Old	U+E662 salt
V	U+E664	keyboardPedalToe1	
∧	U+E665	keyboardPedalToe2	
⤴	U+E666	keyboardPedalHeelToe	
U∧	U+E674	keyboardPedalHeelToToe	
∧U	U+E675	keyboardPedalToeToHeel	
L	U+E672	keyboardPedalHookStart	
J	U+E673	keyboardPedalHookEnd	
(	U+E676	keyboardPedalParensLeft	
)	U+E677	keyboardPedalParensRight	
🌀	U+E667	keyboardPluckInside	
⋮	U+E668	keyboardBebung2DotsAbove	
⋱	U+E669	keyboardBebung2DotsBelow	
⋮	U+E66A	keyboardBebung3DotsAbove	
⋱	U+E66B	keyboardBebung3DotsBelow	
⋮	U+E66C	keyboardBebung4DotsAbove	
⋱	U+E66D	keyboardBebung4DotsBelow	
L	U+E66E	keyboardPlayWithRH	
J	U+E66F	keyboardPlayWithRHEnd	
┌	U+E670	keyboardPlayWithLH	
┐	U+E671	keyboardPlayWithLHEnd	
	U+1F3B9	Keyboard	
	U+1F398	MIDI keyboard	

## Accordion

	U+E8BB	accdnLH2Ranks8Round
	U+E8BC	accdnLH2Ranks16Round
	U+E8BD	accdnLH2Ranks8Plus16Round
	U+E8BE	accdnLH2RanksMasterRound
	U+E8BF	accdnLH2RanksMasterPlus16Round
	U+E8C0	accdnLH2RanksFullMasterRound
	U+E8A0	accdnRH3RanksPiccolo
	U+E8A1	accdnRH3RanksClarinet
	U+E8A2	accdnRH3RanksUpperTremolo8
	U+E8A3	accdnRH3RanksLowerTremolo8
	U+E8A4	accdnRH3RanksBassoon
	U+E8A5	accdnRH3RanksOboe
	U+E8A6	accdnRH3RanksViolin
	U+E8A7	accdnRH3RanksImitationMusette
	U+E8A8	accdnRH3RanksAuthenticMusette
	U+E8A9	accdnRH3RanksOrgan
	U+E8AA	accdnRH3RanksHarmonium
	U+E8AB	accdnRH3RanksBandoneon
	U+E8AC	accdnRH3RanksAccordion
	U+E8AD	accdnRH3RanksMaster
	U+E8AE	accdnRH3RanksTwoChoirs
	U+E8AF	accdnRH3RanksTremoloLower8ve
	U+E8B0	accdnRH3RanksTremoloUpper8ve
	U+E8B1	accdnRH3RanksDoubleTremoloLower8ve
	U+E8B2	accdnRH3RanksDoubleTremoloUpper8ve
	U+E8B3	accdnRH3RanksFullFactory

## Accordion

	U+E8B4	accdnRH4RanksSoprano
	U+E8B5	accdnRH4RanksAlto
	U+E8B6	accdnRH4RanksTenor
	U+E8B7	accdnRH4RanksMaster
	U+E8B8	accdnRH4RanksSoftBass
	U+E8B9	accdnRH4RanksSoftTenor
	U+E8BA	accdnRH4RanksBassAlto
	U+E8C1	accdnLH3Ranks8Square
	U+E8C2	accdnLH3Ranks2Square
	U+E8C3	accdnLH3RanksDouble8Square
	U+E8C4	accdnLH3Ranks2Plus8Square
	U+E8C5	accdnLH3RanksTuttiSquare
	U+E8C8	accdnCombLH2RanksEmpty
	U+E8C6	accdnCombRH3RanksEmpty
	U+E8C7	accdnCombRH4RanksEmpty
	U+E8C9	accdnCombLH3RanksEmptySquare
	U+E8CA	accdnCombDot

## Accordion







>	U+E8CB	accdnPush
┘	U+E8CC	accdnPull
⤵	U+E8CD	accdnRicochet2
⤴	U+E8CE	accdnRicochet3
⤶	U+E8CF	accdnRicochet4
⤷	U+E8D0	accdnRicochet5
⤸	U+E8D1	accdnRicochet6
↘	U+E8D2	accdnRicochetStem2
↙	U+E8D3	accdnRicochetStem3
↗	U+E8D4	accdnRicochetStem4
↖	U+E8D5	accdnRicochetStem5
↕	U+E8D6	accdnRicochetStem6
	U+1FA97	Accordion

## Percussion instruments

---

✱	U+E7F0	pictStickShot
Ⓝ	U+E804	pictNormalPosition
⊗	U+E7FE	pictCenter1
⊙	U+E7FF	pictCenter2
©	U+E800	pictCenter3
■	U+E7F4	pictOnRim
✱	U+E7FD	pictRimShotOnStem
⊗	U+E801	pictRim1
⊙	U+E802	pictRim2
®	U+E803	pictRim3
+	U+E7F5	pictOpenRimShot
⊕	U+E7F6	pictHalfOpen1
⊖	U+E7F7	pictHalfOpen2
○	U+E7F8	pictOpen
⊕	U+E7F9	pictDamp1
⊕	U+E7FA	pictDamp2
⊕	U+E7FB	pictDamp3
⊕	U+E7FC	pictDamp4
,	U+E805	pictChokeCymbal
□	U+E806	pictRightHandSquare
•	U+E807	pictLeftHandCircle
⊙	U+E7F1	pictScrapeCenterToEdge
⊙	U+E7F2	pictScrapeEdgeToCenter
⊙	U+E7F3	pictScrapeAroundRim
⊙	U+E80E	pictScrapeAroundRimClockwise

## Percussion instruments

























	U+E808	pictSwishStem
	U+E809	pictTurnRightStem
	U+E80A	pictTurnLeftStem
	U+E80B	pictTurnRightLeftStem
	U+E80C	pictCrushStem
	U+E80D	pictDeadNoteStem

## Handbells



























▼	U+E810	handbellsMartellato
▼↑	U+E811	handbellsMartellatoLift
◄	U+E812	handbellsHandMartellato
◉	U+E813	handbellsMutedMartellato
+	U+E814	handbellsMalletBellSuspended
⊕	U+E815	handbellsMalletBellOnTable
⊕↑	U+E816	handbellsMalletLft
↑	U+E817	handbellsPluckLift
↑	U+E818	handbellsSwingUp
↓	U+E819	handbellsSwingDown
↕	U+E81A	handbellsSwing
↕	U+E81B	handbellsEcho1
↕	U+E81C	handbellsEcho2
↻	U+E81D	handbellsGyro
⊕	U+E81E	handbellsDamp3
⌘	U+E81F	handbellsBelltree
↘	U+E820	handbellsTableSingleBell
↘	U+E821	handbellsTablePairBells



























## Beaters pictograms

	U+E770	pictBeaterSoftXylophoneUp
	U+E771	pictBeaterSoftXylophoneDown
	U+E772	pictBeaterSoftXylophoneRight
	U+E773	pictBeaterSoftXylophoneLeft
	U+E7DB	pictBeaterSoftXylophone
	U+E774	pictBeaterMediumXylophoneUp
	U+E775	pictBeaterMediumXylophoneDown
	U+E776	pictBeaterMediumXylophoneRight
	U+E777	pictBeaterMediumXylophoneLeft
	U+E778	pictBeaterHardXylophoneUp
	U+E779	pictBeaterHardXylophoneDown
	U+E77A	pictBeaterHardXylophoneRight
	U+E77B	pictBeaterHardXylophoneLeft
	U+E77C	pictBeaterWoodXylophoneUp
	U+E77D	pictBeaterWoodXylophoneDown
	U+E77E	pictBeaterWoodXylophoneRight
	U+E77F	pictBeaterWoodXylophoneLeft
	U+E780	pictBeaterSoftGlockenspielUp
	U+E781	pictBeaterSoftGlockenspielDown
	U+E782	pictBeaterSoftGlockenspielRight
	U+E783	pictBeaterSoftGlockenspielLeft
	U+E784	pictBeaterHardGlockenspielUp
	U+E785	pictBeaterHardGlockenspielDown
	U+E786	pictBeaterHardGlockenspielRight
	U+E787	pictBeaterHardGlockenspielLeft



























## Beaters pictograms

	U+E788	pictBeaterSoftTimpaniUp
	U+E789	pictBeaterSoftTimpaniDown
	U+E78A	pictBeaterSoftTimpaniRight
	U+E78B	pictBeaterSoftTimpaniLeft
	U+E78C	pictBeaterMediumTimpaniUp
	U+E78D	pictBeaterMediumTimpaniDown
	U+E78E	pictBeaterMediumTimpaniRight
	U+E78F	pictBeaterMediumTimpaniLeft
	U+E790	pictBeaterHardTimpaniUp
	U+E791	pictBeaterHardTimpaniDown
	U+E792	pictBeaterHardTimpaniRight
	U+E793	pictBeaterHardTimpaniLeft
	U+E794	pictBeaterWoodTimpaniUp
	U+E795	pictBeaterWoodTimpaniDown
	U+E796	pictBeaterWoodTimpaniRight
	U+E797	pictBeaterWoodTimpaniLeft
	U+E798	pictBeaterSoftBassDrumUp
	U+E799	pictBeaterSoftBassDrumDown
	U+E79A	pictBeaterMediumBassDrumUp
	U+E79B	pictBeaterMediumBassDrumDown
	U+E79C	pictBeaterHardBassDrumUp
	U+E79D	pictBeaterHardBassDrumDown
	U+E79E	pictBeaterMetalBassDrumUp
	U+E79F	pictBeaterMetalBassDrumDown
	U+E7A0	pictBeaterDoubleBassDrumUp
	U+E7A1	pictBeaterDoubleBassDrumDown



























## Beaters pictograms

	U+E7A2	pictBeaterSoftYarnUp
	U+E7A3	pictBeaterSoftYarnDown
	U+E7A4	pictBeaterSoftYarnRight
	U+E7A5	pictBeaterSoftYarnLeft
	U+E7A6	pictBeaterMediumYarnUp
	U+E7A7	pictBeaterMediumYarnDown
	U+E7A8	pictBeaterMediumYarnRight
	U+E7A9	pictBeaterMediumYarnLeft
	U+E7AA	pictBeaterHardYarnUp
	U+E7AB	pictBeaterHardYarnDown
	U+E7AC	pictBeaterHardYarnRight
	U+E7AD	pictBeaterHardYarnLeft
	U+E7AE	pictBeaterSuperballUp
	U+E7AF	pictBeaterSuperballDown
	U+E7B0	pictBeaterSuperballRight
	U+E7B1	pictBeaterSuperballLeft
	U+E7B2	pictSuperball
	U+E7B3	pictWoundHardUp
	U+E7B4	pictWoundHardDown
	U+E7B5	pictWoundHardRight
	U+E7B6	pictWoundHardLeft
	U+E7B7	pictWoundSoftUp
	U+E7B8	pictWoundSoftDown
	U+E7B9	pictWoundSoftRight
	U+E7BA	pictWoundSoftLeft

## Beaters pictograms



	U+E7BB	pictGumSoftUp
	U+E7BC	pictGumSoftDown
	U+E7BD	pictGumSoftRight
	U+E7BE	pictGumSoftLeft
	U+E7BF	pictGumMediumUp
	U+E7C0	pictGumMediumDown
	U+E7C1	pictGumMediumRight
	U+E7C2	pictGumMediumLeft
	U+E7C3	pictGumHardUp
	U+E7C4	pictGumHardDown
	U+E7C5	pictGumHardRight
	U+E7C6	pictGumHardLeft
	U+E7C7	pictBeaterMetalUp
	U+E7C8	pictBeaterMetalDown
	U+E7C9	pictBeaterMetalRight
	U+E7CA	pictBeaterMetalLeft
	U+E7CB	pictBeaterHammerWoodUp
	U+E7CC	pictBeaterHammerWoodDown
	U+E7CD	pictBeaterHammerPlasticUp
	U+E7CE	pictBeaterHammerPlasticDown
	U+E7CF	pictBeaterHammerMetalUp
	U+E7D0	pictBeaterHammerMetalDown
	U+E7DF	pictBeaterMallet
	U+E7EC	pictBeaterMalletDown
	U+E7E0	pictBeaterMetalHammer
	U+E7E1	pictBeaterHammer

## Beaters pictograms































	U+E7E8	pictDrumStick
	U+E7D1	pictBeaterSnareSticksUp
	U+E7D2	pictBeaterSnareSticksDown
	U+E7D3	pictBeaterJazzSticksUp
	U+E7D4	pictBeaterJazzSticksDown
	U+E7D5	pictBeaterTriangleUp
	U+E7D6	pictBeaterTriangleDown
	U+E7EF	pictBeaterTrianglePlain
	U+E7D7	pictBeaterWireBrushesUp
	U+E7D8	pictBeaterWireBrushesDown
	U+E7D9	pictBeaterBrassMalletsUp
	U+E7DA	pictBeaterBrassMalletsDown
	U+E7ED	pictBeaterBrassMalletsRight
	U+E7EE	pictBeaterBrassMalletsLeft
	U+E7DC	pictBeaterSpoonWoodenMallet
	U+E7DD	pictBeaterGuiroScraper
	U+E7DE	pictBeaterBow
	U+E7E2	pictBeaterKnittingNeedle
	U+E7E7	pictCoins
	U+E7E3	pictBeaterHand
	U+E7E4	pictBeaterFinger
	U+E7E5	pictBeaterFist
	U+E7E6	pictBeaterFingernails
	U+E7E9	pictBeaterCombiningParentheses
	U+E7EA	pictBeaterCombiningDashedCircle
	U+E7EB	pictBeaterBox

## Percussion pictograms



## Tuned mallet percussion pictograms

	U+E6A0	pictGisp	
	U+F4AA	pictGispPeinkofer	U+E6A0 salt
	U+E6AA	pictGispSmithBrindle	
	U+E6A1	pictXyl	
	U+F4A9	pictXylPeinkofer	U+E6A1 salt
	U+E6AB	pictXylSmithBrindle	
	U+E6A4	pictXylTrough	
	U+E6A2	pictXylTenor	
	U+F4A4	pictXylTenorPeinkofer	U+E6A2 salt
	U+E6A5	pictXylTenorTrough	
	U+E6A3	pictXylBass	
	U+F4A3	pictXylBassPeinkofer	U+E6A3 salt
	U+E6A6	pictMar	
	U+F4AB	pictMarPeinkofer	U+E6A6 salt
	U+E6AC	pictMarSmithBrindle	
	U+E6A7	pictVib	
	U+F4A5	pictVibPeinkofer	U+E6A7 salt
	U+E6AD	pictVibSmithBrindle	
	U+E6A8	pictVibMotorOff	
	U+F4A6	pictVibMotorOffPeinkofer	U+E6A8 salt
	U+E6B2	pictTubaphone	
	U+F4A8	pictTubaphonePeinkofer	U+E6B2 salt
	U+E6B0	pictCelesta	
	U+E6B1	pictLithophone	
	U+F4A7	pictLithophonePeinkofer	U+E6B1 salt
	U+E6A9	pictEmptyTrap	
	U+E6AE	pictCrotales	
	U+E6AF	pictSteelDrums	

















## Drums pictograms

	U+E6D0		pictTimpani	
	U+F4AE		pictTimpaniPeinkofer	U+E6D0 salt
	U+E6D1		pictSnareDrum	
	U+E6D2		pictSnareDrumSnaresOff	
	U+E6D3		pictSnareDrumMilitary	
		U+1F941	Drum with drumsticks	
	U+F6E0		pictDrumSet	
	U+E6D4		pictBassDrum	
	U+E6D5		pictBassDrumOnSide	
	U+F4AF		pictBassDrumPeinkofer	U+E6D4 salt
	U+F6E8		pictBedug	
	U+E6D6		pictTenorDrum	
	U+E6D7		pictTomTom	
	U+F4B2		pictTomTomPeinkofer	U+E6D7 salt
	U+E6D8		pictTomTomChinese	
	U+F4AD		pictTomTomChinesePeinkofer	U+E6D8 salt
	U+F6E9		pictDagu	
	U+E6D9		pictTomTomJapanese	
	U+E6DA		pictTomTomIndoAmerican	
	U+E6DB		pictTambourine	
	U+F438		pictTambourineStockhausen	U+E6DB salt
	U+E6DC		pictTimbales	
	U+F4B3		pictTimbalesPeinkofer	U+E6DC salt
	U+E6DD		pictBongos	
	U+F4B0		pictBongosPeinkofer	U+E6DD salt
	U+E6E3		pictTabla	
	U+E6DE		pictConga	
	U+F4B1		pictCongaPeinkofer	U+E6DE salt
		U+1FA98	Long drum	
	U+F6E1		pictDjembe	

## Drums pictograms

	U+E6DF	pictLogDrum
	U+E6E0	pictSlitDrum
	U+E6E1	pictBrakeDrum
	U+E6E2	pictGobletDrum
	U+E6E4	pictCuica

## Wooden struck or scraped percussion pictograms



	U+E6F0	pictWoodBlock	
	U+E6F1	pictTempleBlocks	
	U+E6F2	pictClaves	
	U+E6F3	pictGuiro	
	U+F4B4	pictGuiroSevsay	U+E6F3 salt 1
	U+F4B5	pictGuiroPeinkofer	U+E6F3 salt 2
	U+E6F4	pictRatchet	
	U+E6F5	pictFootballRatchet	
	U+E6F6	pictWhip	
	U+E6F7	pictBoardClapper	
	U+E6F8	pictCastanets	
	U+F439	pictCastanetsSmithBrindle	U+E6F8 salt
	U+E6F9	pictCastanetsWithHandle	
	U+E6FA	pictQuijada	
	U+E6FB	pictBambooScraper	
	U+F6E2	pictBambooScraper2	U+E6FB salt
	U+E6FC	pictRecoReco	

## Metallic struck percussion pictograms











	U+E700	pictTriangle
	U+E701	pictAnvil













## Chimes pictograms

	U+E6C0	pictTubularBells
	U+E6C1	pictWindChimesGlass
	U+E6C2	pictChimes
	U+E6C3	pictBambooChimes
	U+E6C4	pictShellChimes
	U+E6C5	pictGlassTubeChimes
	U+E6C6	pictGlassPlateChimes
	U+E6C7	pictMetalTubeChimes
	U+E6C8	pictMetalPlateChimes





## Bells pictograms

	U+E710	pictSleighBell	
	U+F43A	pictSleighBellSmithBridle	U+E710 salt
	U+E711	pictCowBell	
	U+F43B	pictCowBellBerio	U+E711 salt
	U+E712	pictAlmglocken	
	U+E713	pictBellPlate	
	U+E714	pictBell	
	U+E715	pictHandbell	
	U+E716	pictCencerro	
	U+E717	pictAgogo	
	U+E718	pictShellBells	
	U+E719	pictJingleBells	
	U+E71A	pictBellTree	









## Cymbals pictograms

	U+E720	pictCrashCymbals
	U+E721	pictSuspendedCymbal
	U+E722	pictHiHat
	U+E723	pictHiHatOnStand
	U+E724	pictSizzleCymbal
	U+E725	pictVietnameseHat
	U+E726	pictChineseCymbal
	U+E727	pictFingerCymbals
	U+E728	pictCymbalTongs
	U+E729	pictEdgeOfCymbal
	U+E72A	pictBellOfCymbal













## Gongs pictograms

	U+E730	pictTamTam
	U+E731	pictTamTamWithBeater
	U+E732	pictGong
	U+E733	pictGongWithButton
	U+E734	pictSlideBrushOnGong









## Shakers or rattles pictograms

	U+E740	pictFlexatone	
	U+F4B6	pictFlexatonePeinkofer	U+E740 salt
	U+E741	pictMaraca	
	U+F43C	pictMaracaSmithBrindle	U+E741 salt
	U+E742	pictMaracas	
	U+1FA87	Maracas	
	U+E743	pictCabasa	
	U+E744	pictThundersheet	
	U+E745	pictVibraslap	
	U+E746	pictSistrum	
	U+E747	pictRainstick	
	U+E748	pictChainRattle	
	U+F6E3	pictAngklung	
	U+F6E4	pictPelletDrum	

## Whistles and aerophones pictograms

	U+E750	pictSlideWhistle	
	U+E751	pictBirdWhistle	
	U+E752	pictPoliceWhistle	
	U+E753	pictSiren	
	U+E754	pictWindMachine	
	U+E755	pictCarHorn	
	U+E756	pictKlaxonHorn	
	U+E757	pictDuckCall	
	U+E758	pictWindWhistle	
	U+E759	pictMegaphone	
	U+E75A	pictLotusFlute	
	U+F4AC	pictLotusFlutePeinkofer	U+E75A salt

## Miscellaneous percussion instrument pictograms

	U+E760	pictPistolShot	
	U+E761	pictCannon	
	U+E762	pictSandpaperBlocks	
	U+E763	pictLionsRoar	
	U+E764	pictGlassHarp	
	U+E765	pictGlassHarmonica	
	U+E766	pictMusicalSaw	
	U+F4B7	pictMusicalSawPeinkofer	U+E766 salt
	U+E767	pictJawHarp	

Vocals

























---

—	U+E640	vocalMouthClosed
▬	U+E641	vocalMouthSlightlyOpen
□	U+E642	vocalMouthOpen
□	U+E643	vocalMouthWideOpen
◻	U+E644	vocalMouthPursed
✕	U+E645	vocalSprechgesang
†	U+E64B	vocalHalbGesungen
§	U+E646	vocalsSussurando
Δ	U+E647	vocalNasalVoice
⋈	U+E648	vocalTongueClickStockhausen
⋈	U+E649	vocalFingerClickStockhausen
⋈	U+E64A	vocalTongueFingerClickStockhausen























## Lyrics

˘	U+E550	lyricsElisionNarrow
˘	U+E551	lyricsElision
˘	U+E552	lyricsElisionWide
–	U+E553	lyricsHyphenBaseline
–	U+E554	lyricsHyphenBaselineNonBreaking
⌘	U+E555	lyricsTextRepeat









## Electronic music

	U+EB13	U+1F4BF	elecDisc
		U+1F4C0	DVD
		U+1F5B8	Optical disc icon
	U+EB14		elecTape
		U+2707	Tape drive
	U+EB3C		elecAudioMono
	U+EB3D		elecAudioStereo
	U+EB3E		elecAudioChannelsOne
	U+EB3F		elecAudioChannelsTwo
	U+EB40		elecAudioChannelsThreeFrontal
	U+EB41		elecAudioChannelsThreeSurround
	U+EB42		elecAudioChannelsFour
	U+EB43		elecAudioChannelsFive
	U+EB44		elecAudioChannelsSix
	U+EB45		elecAudioChannelsSeven
	U+EB46		elecAudioChannelsEight
	U+EB2C		elecVolumeFader
	U+EB2D		elecVolumeFaderThumb
	U+EB2E		elecVolumeLevel0
	U+EB2F		elecVolumeLevel20
	U+EB30		elecVolumeLevel40
	U+EB31		elecVolumeLevel60
	U+EB32		elecVolumeLevel80
	U+EB33		elecVolumeLevel100

## Electronic music























	U+F6D2	elecMIDIController
	U+F6D3	elecMIDIControllerThumb
	U+EB36	elecMIDIController0
	U+EB37	elecMIDIController20
	U+EB38	elecMIDIController40
	U+EB39	elecMIDIController60
	U+EB3A	elecMIDIController80
	U+EB3B	elecMIDIController100
	U+EB15	elecMixingConsole
	U+1F39A	Level control
	U+1F39B	Audio control
	U+EB16	elecUSB
	U+EB47	elecLineIn
	U+EB48	elecLineOut
	U+F65C	elecSurroundSound
	U+F65D	elecCenterSubwoofer
	U+F65E	elecSideSurroundSound
	U+EB49	elecAudioIn
	U+EB4A	elecAudioOut
	U+F6E5	elecAudioFile
	U+EB34	elecMIDIIn
	U+EB35	elecMIDIOut
	U+F6E7	elecMIDIFile

## Electronic music























	U+EB4B	elecVideoIn
	U+EB4C	elecVideoOut
	U+F6E6	elecVideoFile
	U+EB4D	elecDataIn
	U+EB4E	elecDataOut
	U+F642	elecDataFile
	U+EB4F	elecDownload
	U+EB50	elecUpload































## Communication symbols

	U+EB10		elecMicrophone
	U+EB28		elecMicrophoneMute
	U+EB29		elecMicrophoneUnmute
		U+1F3A4	Microphone
		U+1F399	Studio microphone
	U+EB11	U+1F3A7	elecHeadphones
	U+EB12		elecHeadset
	U+EB1A	U+1F508	elecLoudspeaker
		U+1F568	Right speaker
	U+EB26		elecMute
	U+F659		elecMuteRight
		U+1F507	Speaker with cancellation stroke
	U+F65B		elecMuteStrokeRight
	U+EB27		elecUnmute
	U+F65A		elecUnmuteRight
		U+1F509	Speaker with one sound wave
		U+1F569	Right speaker with one sound wave
		U+1F50A	Speaker with three sound waves
		U+1F56A	Right speaker with three sound waves
		U+1F56B	Bullhorn, Sound off
		U+1F56C	Bullhorn, Sound on
		U+1F4E2	Public address loudspeaker
		U+1F4E3	Cheering megaphone































## Communication symbols

		U+1F514	Bell
		U+1F515	Bell with cancellation stroke
		U+1F56D	Ringling bell
	U+EB1B	U+1F4F7	elecCamera
		U+1F4F8	Camera with flash
	U+EB17	U+1F4F9	elecVideoCamera
		U+1F3A5	Movie camera
	U+EB18		elecMonitor
		U+1F5B5	Screen
		U+1F4FA	Television
	U+EB19		elecProjector
		U+1F39E	Film frames, Film
		U+1F3AC	Clapper board, Film
		U+269E	Three lines converging right, Someone speaking
		U+269F	Three lines converging left, Background speaking
		U+1F5E8	Speech bubble left
		U+1F5E9	Speech bubble right
		U+1F4AC	Speech balloon, Conversation bubble
		U+1F5EA	Two speech bubbles
		U+1F5EE	Shout left
		U+1F5EF	Shout right
		U+1F5F0	Mood bubble, New
		U+1F5E3	Speaking head















## User interface symbols

	U+EB2A		elecPowerOnOff
	U+EB1C		elecPlay
		U+23FA	Record
	U+EB1D	U+23F9	elecStop
	U+EB1E	U+23F8	elecPause
	U+EB2B	U+23CF	elecEject
	U+EB1F		elecFastForward
	U+EB20		elecRewind
		U+23E9	Fast forward
		U+23EA	Fast rewind
		U+23EB	Increase
		U+23EC	Decrease
	U+EB21		elecSkipForwards
	U+EB22		elecSkipBackwards
		U+23ED	Skip forward
		U+23EE	Skip backward
		U+23EF	Skip, Pause
		U+23F4	Reverse, Back
		U+23F5	Forward
		U+23F6	Increase
		U+23F7	Decrease
	U+EB23		elecLoop
		U+2B94	Four circling arrows, Loop
	U+EB24		elecReplay
		U+1F501	Repeat
		U+1F502	Repeat one item over
		U+1F503	Reload
		U+1F504	Reload
	U+EB25	U+1F500	elecShuffle

## User interface symbols

	U+1F505	Low brightness
	U+1F506	High brightness
	U+1F5E4	Three rays above
	U+1F5E5	Three rays below
	U+1F5E6	Three rays left
	U+1F5E7	Three rays right
	U+231A	Watch
	U+23F0	Alarm clock
	U+23F1	Stop watch
	U+23F2	Timer clock
	U+231B	Hourglass
	U+23F3	Hourglass with flowing sand
	U+1F5CB	Empty document
	U+1F5CE	Document
	U+1F5B9	Text document
	U+1F5BA	Text and graphic document
	U+1F5BB	Graphic document
	U+1F5CC	Empty page
	U+1F5CD	Empty pages
	U+1F5CF	Page
	U+1F5D0	Pages
	U+1F5BF	Black folder
	U+1F5C0	Folder, Directory
	U+1F5C1	Open folder
	U+1F4CB	Clipboard
	U+1F517	Link
	U+1F5DA	Increase font size
	U+1F5DB	Decrease font size
	U+1F5D8	Refresh
	U+1F5D9	Cancellation, Close

## User interface symbols

	U+2328	Keyboard
	U+23CE	Return
	U+21B4	Line feed
	U+21B5	Carriage return, New line
	U+2324	Enter
	U+2325	Option
	U+2326	Delete to the right
	U+232B	Delete to the left
	U+2327	Clear
	U+21B8	Home
	U+21E4	Leftward tab
	U+21E5	Rightwards tab
	U+21B9	Tab and Shift Tab
	U+2B7E	Horizontal tab
	U+2B7F	Vertical tab

Time signatures

---

<b>0</b>	U+E080		timeSig0
<b>1</b>	U+E081		timeSig1
<b>2</b>	U+E082		timeSig2
<b>3</b>	U+E083		timeSig3
<b>4</b>	U+E084		timeSig4
<b>5</b>	U+E085		timeSig5
<b>6</b>	U+E086		timeSig6
<b>7</b>	U+E087		timeSig7
<b>8</b>	U+E088		timeSig8
<b>9</b>	U+E089		timeSig9
<b>©</b>	U+E08A	U+1D134	timeSigCommon
<b>Ⓒ</b>	U+E08B	U+1D135	timeSigCutCommon
<b>¢</b>	U+EC85		timeSigCut2
<b>₹</b>	U+EC86		timeSigCut3
<b>ℵ</b>	U+E09C		timeSigX
<b>∞</b>	U+E09D		timeSigOpenPenderecki
<b>+</b>	U+E08C		timeSigPlus
<b>+</b>	U+E08D		timeSigPlusSmall
<b>/</b>	U+E08E		timeSigFractionalSlash
<b>=</b>	U+E08F		timeSigEquals
<b>-</b>	U+E090		timeSigMinus
<b>×</b>	U+E091		timeSigMultiply
<b>,</b>	U+E096		timeSigComma
<b>/</b>	U+EC84		timeSigSlash

## Time signatures

(	U+E092	timeSigParensLeftSmall
)	U+E093	timeSigParensRightSmall
(	U+E094	timeSigParensLeft
)	U+E095	timeSigParensRight
[	U+EC82	timeSigBracketLeftSmall
]	U+EC83	timeSigBracketRightSmall
[	U+EC80	timeSigBracketLeft
]	U+EC81	timeSigBracketRight
$\frac{1}{4}$	U+E097	timeSigFractionQuarter
$\frac{1}{2}$	U+E098	timeSigFractionHalf
$\frac{3}{4}$	U+E099	timeSigFractionThreeQuarters
$\frac{1}{3}$	U+E09A	timeSigFractionOneThird
$\frac{2}{3}$	U+E09B	timeSigFractionTwoThirds
	U+E09E	timeSigCombNumerator
	U+E09F	timeSigCombDenominator
$\frac{2}{4}$	U+F57B	timeSig2over4 U+E09E U+E082 U+E09F U+E084
$\frac{2}{2}$	U+F57C	timeSig2over2 U+E09E U+E082 U+E09F U+E082
$\frac{3}{2}$	U+F57D	timeSig3over2 U+E09E U+E083 U+E09F U+E082
$\frac{3}{4}$	U+F57E	timeSig3over4 U+E09E U+E083 U+E09F U+E084
$\frac{3}{8}$	U+F57F	timeSig3over8 U+E09E U+E083 U+E09F U+E088
$\frac{4}{4}$	U+F580	timeSig4over4 U+E09E U+E084 U+E09F U+E084
$\frac{5}{4}$	U+F581	timeSig5over4 U+E09E U+E085 U+E09F U+E084

## Time signatures

$\frac{5}{8}$	U+F582	timeSig5over8 U+E09E U+E085 U+E09F U+E088
$\frac{6}{4}$	U+F583	timeSig6over4 U+E09E U+E086 U+E09F U+E084
$\frac{6}{8}$	U+F584	timeSig6over8 U+E09E U+E086 U+E09F U+E088
$\frac{7}{8}$	U+F585	timeSig7over8 U+E09E U+E087 U+E09F U+E088
$\frac{9}{8}$	U+F586	timeSig9over8 U+E09E U+E089 U+E09F U+E088
$\frac{12}{8}$	U+F587	timeSig12over8 U+E09E U+E081 U+E09E U+E082 U+E09F U+E088
0	U+F5C8	timeSig0Denominator U+E09F U+E080
0	U+F5C9	timeSig0Numerator U+E09E U+E080
1	U+F5CA	timeSig1Denominator U+E09F U+E081
1	U+F5CB	timeSig1Numerator U+E09E U+E081
2	U+F5CC	timeSig2Denominator U+E09F U+E082
2	U+F5CD	timeSig2Numerator U+E09E U+E082
3	U+F5CE	timeSig3Denominator U+E09F U+E083
3	U+F5CF	timeSig3Numerator U+E09E U+E083
4	U+F5D0	timeSig4Denominator U+E09F U+E084
4	U+F5D1	timeSig4Numerator U+E09E U+E084
5	U+F5D2	timeSig5Denominator U+E09F U+E085
5	U+F5D3	timeSig5Numerator U+E09E U+E085



## Time signatures

<b>6</b>	U+F5D4	timeSig6Denominator U+E09F U+E086
<b>6</b>	U+F5D5	timeSig6Numerator U+E09E U+E086
<b>7</b>	U+F5D6	timeSig7Denominator U+E09F U+E087
<b>7</b>	U+F5D7	timeSig7Numerator U+E09E U+E087
<b>8</b>	U+F5D8	timeSig8Denominator U+E09F U+E088
<b>8</b>	U+F5D9	timeSig8Numerator U+E09E U+E088
<b>9</b>	U+F5DA	timeSig9Denominator U+E09F U+E089
<b>9</b>	U+F5DB	timeSig9Numerator U+E09E U+E089

## Turned time signatures

<b>0</b>	U+ECE0	timeSig0Turned
<b>1</b>	U+ECE1	timeSig1Turned
<b>2</b>	U+ECE2	timeSig2Turned
<b>3</b>	U+ECE3	timeSig3Turned
<b>4</b>	U+ECE4	timeSig4Turned
<b>5</b>	U+ECE5	timeSig5Turned
<b>6</b>	U+ECE6	timeSig6Turned
<b>7</b>	U+ECE7	timeSig7Turned
<b>8</b>	U+ECE8	timeSig8Turned
<b>9</b>	U+ECE9	timeSig9Turned
<b>0</b>	U+ECEA	timeSigCommonTurned
<b>0</b>	U+ECEB	timeSigCutCommonTurned

## Reversed time signatures

<b>0</b>	U+ECF0	timeSig0Reversed
<b>1</b>	U+ECF1	timeSig1Reversed
<b>2</b>	U+ECF2	timeSig2Reversed
<b>3</b>	U+ECF3	timeSig3Reversed
<b>4</b>	U+ECF4	timeSig4Reversed
<b>5</b>	U+ECF5	timeSig5Reversed
<b>6</b>	U+ECF6	timeSig6Reversed
<b>7</b>	U+ECF7	timeSig7Reversed
<b>8</b>	U+ECF8	timeSig8Reversed
<b>9</b>	U+ECF9	timeSig9Reversed
<b>⓪</b>	U+ECFA	timeSigCommonReversed
<b>ⓑ</b>	U+ECFB	timeSigCutCommonReversed

## Octaves

---

<i>8</i>	U+E510		ottava
<i>8<sup>va</sup></i>	U+E511	U+1D136	ottavaAlta
<i>8<sub>va</sub></i>	U+E512	U+1D137	ottavaBassa
<i>8<sub>ba</sub></i>	U+E513		ottavaBassaBa
<i>8<sub>vb</sub></i>	U+E51C		ottavaBassaVb
<i>8<sup>vb</sup></i>	U+F652		ottavaBassaSupVb
<i>15</i>	U+E514		quindicesima
<i>15<sup>ma</sup></i>	U+E515	U+1D138	quindicesimaAlta
<i>15<sub>ma</sub></i>	U+E516	U+1D139	quindicesimaBassa
<i>15<sub>mb</sub></i>	U+E51D		quindicesimaBassaMb
<i>15<sup>mb</sup></i>	U+F653		quindicesimaBassaSupMb
<i>22</i>	U+E517		ventiduesima
<i>22<sup>ma</sup></i>	U+E518		ventiduesimaAlta
<i>22<sub>ma</sub></i>	U+E519		ventiduesimaBassa
<i>22<sub>mb</sub></i>	U+E51E		ventiduesimaBassaMb
<i>22<sup>mb</sup></i>	U+F654		ventiduesimaBassaSupMb
<i>29</i>	U+F6F8		ventinovesima
<i>29<sup>ma</sup></i>	U+F6F9		ventinovesimaAlta
<i>29<sub>ma</sub></i>	U+F6FA		ventinovesimaBassa
<i>29<sub>mb</sub></i>	U+F6FB		ventinovesimaBassaMb
<i>29<sup>mb</sup></i>	U+F655		ventinovesimaBassaSupMb
<i>bassa</i>	U+E51F		octaveBassa
<i>loco</i>	U+EC90		octaveLoco
<i>a</i>	U+EC91		octaveBaselineA
<i>a</i>	U+EC92		octaveSuperscriptA
<i>b</i>	U+EC93		octaveBaselineB
<i>b</i>	U+EC94		octaveSuperscriptB
<i>m</i>	U+EC95		octaveBaselineM
<i>m</i>	U+EC96		octaveSuperscriptM
<i>v</i>	U+EC97		octaveBaselineV
<i>v</i>	U+EC98		octaveSuperscriptV
(	U+E51A		octaveParensLeft
)	U+E51B		octaveParensRight

## Tuplets

---

<i>0</i>	U+E880	tuplet0
<i>1</i>	U+E881	tuplet1
<i>2</i>	U+E882	tuplet2
<i>3</i>	U+E883	tuplet3
<i>4</i>	U+E884	tuplet4
<i>5</i>	U+E885	tuplet5
<i>6</i>	U+E886	tuplet6
<i>7</i>	U+E887	tuplet7
<i>8</i>	U+E888	tuplet8
<i>9</i>	U+E889	tuplet9
<i>:</i>	U+E88A	tupletColon

Fingering

---

0	U+ED10	fingering0
1	U+ED11	fingering1
2	U+ED12	fingering2
3	U+ED13	fingering3
4	U+ED14	fingering4
5	U+ED15	fingering5
6	U+ED24	fingering6
7	U+ED25	fingering7
8	U+ED26	fingering8
9	U+ED27	fingering9
<i>0</i>	U+ED80	fingering0Italic
<i>1</i>	U+ED81	fingering1Italic
<i>2</i>	U+ED82	fingering2Italic
<i>3</i>	U+ED83	fingering3Italic
<i>4</i>	U+ED84	fingering4Italic
<i>5</i>	U+ED85	fingering5Italic
<i>6</i>	U+ED86	fingering6Italic
<i>7</i>	U+ED87	fingering7Italic
<i>8</i>	U+ED88	fingering8Italic
<i>9</i>	U+ED89	fingering9Italic
<i>T</i>	U+ED16	fingeringTUpper
<i>p</i>	U+ED17	fingeringPLower
<i>t</i>	U+ED18	fingeringTLower
<i>i</i>	U+ED19	fingeringILower
<i>m</i>	U+ED1A	fingeringMLower
<i>a</i>	U+ED1B	fingeringALower
<i>c</i>	U+ED1C	fingeringCLower
<i>x</i>	U+ED1D	fingeringXLower
<i>e</i>	U+ED1E	fingeringELower
<i>o</i>	U+ED1F	fingeringOLower
<i>q</i>	U+ED8E	fingeringQLower
<i>s</i>	U+ED8F	fingeringSLower

## Fingering

ˆ	U+ED20	fingeringSubstitutionAbove
˘	U+ED21	fingeringSubstitutionBelow
-	U+ED22	fingeringSubstitutionDash
[	U+ED23	fingeringMultipleNotes
(	U+ED28	fingeringLeftParenthesis
)	U+ED29	fingeringRightParenthesis
(	U+ED8A	fingeringLeftParenthesisItalic
)	U+ED8B	fingeringRightParenthesisItalic
[	U+ED2A	fingeringLeftBracket
]	U+ED2B	fingeringRightBracket
/	U+ED8C	fingeringLeftBracketItalic
/	U+ED8D	fingeringRightBracketItalic
•	U+ED2C	fingeringSeparatorMiddleDot
◦	U+ED2D	fingeringSeparatorMiddleDotWhite
/	U+ED2E	fingeringSeparatorSlash

## Chord notation

## Chord symbols

o	U+E870	U+1D1A9	csymDiminished
∅	U+E871		csymHalfDiminished
+	U+E872		csymAugmented
△	U+E873		csymMajorSeventh
–	U+E874		csymMinor
(	U+E875		csymParensLeftTall
)	U+E876		csymParensRightTall
[	U+E877		csymBracketLeftTall
]	U+E878		csymBracketRightTall
(	U+E879		csymParensLeftVeryTall
)	U+E87A		csymParensRightVeryTall
/	U+E87B		csymAlteredBassSlash
／	U+E87C		csymDiagonalArrangementSlash



## Standard accidentals for chord symbols

<b>b</b>	U+ED60	csymAccidentalFlat
<b>q</b>	U+ED61	csymAccidentalNatural
<b>#</b>	U+ED62	csymAccidentalSharp
<b>⦿</b>	U+ED63	csymAccidentalDoubleSharp
<b>bb</b>	U+ED64	csymAccidentalDoubleFlat
<b>##</b>	U+ED65	csymAccidentalTripleSharp
<b>bbb</b>	U+ED66	csymAccidentalTripleFlat
<b>⦿⦿</b>	U+F6F6	csymAccidentalQuadrupleSharp
<b>bbbb</b>	U+F6F7	csymAccidentalQuadrupleFlat

## Figured bass











0	U+EA50	figbass0
1	U+EA51	figbass1
2	U+EA52	figbass2
2̣	U+EA53	figbass2Raised
3	U+EA54	figbass3
4	U+EA55	figbass4
4̣	U+EA56	figbass4Raised
5	U+EA57	figbass5
5̣	U+EA58	figbass5Raised1
5̣̣	U+EA59	figbass5Raised2
5̣̣̣	U+EA5A	figbass5Raised3
6	U+EA5B	figbass6
6̣	U+EA5C	figbass6Raised
6̣̣	U+EA6F	figbass6Raised2
7	U+EA5D	figbass7
7̣	U+EA5E	figbass7Raised1
7̣̣	U+EA5F	figbass7Raised2
7̣̣̣	U+ECC0	figbass7Diminished
8	U+EA60	figbass8
9	U+EA61	figbass9
9̣	U+EA62	figbass9Raised
♮	U+EA65	figbassNatural
♭	U+EA64	figbassFlat
♯	U+EA66	figbassSharp
♭♭	U+EA63	figbassDoubleFlat
♯♯	U+EA67	figbassDoubleSharp
♭♭♭	U+ECC1	figbassTripleFlat
♯♯♯	U+ECC2	figbassTripleSharp
+	U+EA6C	figbassPlus
↗	U+EA6D	figbassCombiningRaising
↘	U+EA6E	figbassCombiningLowering

## Figured bass

[	U+EA68	figbassBracketLeft
]	U+EA69	figbassBracketRight
(	U+EA6A	figbassParensLeft
)	U+EA6B	figbassParensRight







## Conductor symbols

---

	U+E890	conductorStrongBeat
	U+E891	conductorLeftBeat
	U+E892	conductorRightBeat
	U+E893	conductorWeakBeat
	U+E89A	conductorUnconducted
	U+E894	conductorBeat2Simple
	U+E895	conductorBeat3Simple
	U+E896	conductorBeat4Simple
	U+E897	conductorBeat2Compound
	U+E898	conductorBeat3Compound
	U+E899	conductorBeat4Compound

## Kodály hand signs

---

	U+EC40	kodalyHandDo
	U+EC41	kodalyHandRe
	U+EC42	kodalyHandMi
	U+EC43	kodalyHandFa
	U+EC44	kodalyHandSo
	U+EC45	kodalyHandLa
	U+EC46	kodalyHandTi

Analytics

---

HF	U+E860	U+1D1A6	analyticsHauptstimme
CHF	U+E86A		analyticsChoralmelodie
RHF	U+E86B		analyticsHauptrhythmus
NF	U+E861	U+1D1A7	analyticsNebenstimme
F	U+E862		analyticsStartStimme
l	U+E863	U+1D1A8	analyticsEndStimme
Th	U+E864		analyticsTheme
rT	U+E865		analyticsThemeRetrograde
CL	U+E866		analyticsThemeRetrogradeInversion
JP	U+E867		analyticsThemeInversion
T	U+E868		analyticsTheme1
L	U+E869		analyticsInversion1

## Function theory symbols

0	U+EA70	functionZero
1	U+EA71	functionOne
2	U+EA72	functionTwo
3	U+EA73	functionThree
4	U+EA74	functionFour
5	U+EA75	functionFive
6	U+EA76	functionSix
7	U+EA77	functionSeven
8	U+EA78	functionEight
9	U+EA79	functionNine
<	U+EA7A	functionLessThan
>	U+EA7C	functionGreaterThan
-	U+EA7B	functionMinus
+	U+EA98	functionPlus
°	U+EA97	functionRing
..	U+EA95	functionRepetition1
∴	U+EA96	functionRepetition2
D	U+EA7F	functionDUpper
∅	U+F644	functionSlashedD
d	U+EA80	functionDLower
Ⓓ	U+EA81	functionDD
∅	U+EA82	functionSlashedDD
S	U+EA89	functionSUpper
s	U+EA8A	functionSLower
ℑ	U+EA7D	functionSSUpper
ℑ	U+EA7E	functionSSLower

## Function theory symbols

<b>F</b>	U+EA99	functionFUpper
<b>G</b>	U+EA83	functionGUpper
<b>g</b>	U+EA84	functionGLower
<b>I</b>	U+EA9A	functionIUpper
<b>i</b>	U+EA9B	functionILower
<b>K</b>	U+EA9C	functionKUpper
<b>k</b>	U+EA9D	functionKLower
<b>L</b>	U+EA9E	functionLUpper
<b>l</b>	U+EA9F	functionLLower
<b>M</b>	U+ED00	functionMUpper
<b>m</b>	U+ED01	functionMLower
<b>N</b>	U+EA85	functionNUpper
<b><sup>N</sup></b>	U+ED02	functionNUpperSuperscript
<b>n</b>	U+EA86	functionNLower
<b>P</b>	U+EA87	functionPUpper
<b>p</b>	U+EA88	functionPLower
<b>r</b>	U+ED03	functionRLower
<b>T</b>	U+EA8B	functionTUpper
<b>t</b>	U+EA8C	functionTLower
<b>V</b>	U+EA8D	functionVUpper
<b>v</b>	U+EA8E	functionVLower
<b>[</b>	U+EA8F	functionBracketLeft
<b>]</b>	U+EA90	functionBracketRight
<b>(</b>	U+EA91	functionParensLeft
<b>)</b>	U+EA92	functionParensRight
<b>&lt;</b>	U+EA93	functionAngleLeft
<b>&gt;</b>	U+EA94	functionAngleRight



## Scale degrees

---

1̂	U+EF00	scaleDegree1
2̂	U+EF01	scaleDegree2
3̂	U+EF02	scaleDegree3
4̂	U+EF03	scaleDegree4
5̂	U+EF04	scaleDegree5
6̂	U+EF05	scaleDegree6
7̂	U+EF06	scaleDegree7
8̂	U+EF07	scaleDegree8
9̂	U+EF08	scaleDegree9

Metrical symbols

---

































←	U+EC63	metricModulationArrowLeft
→	U+EC64	metricModulationArrowRight
˘	U+23D1	Breve
⏞	U+23D2	Long over short
⏚	U+23D3	Short over long
⏛	U+23D4	Long over two shorts
⏜	U+23D5	Two shorts over long
⏝	U+23D6	Two shorts joined
⏞⏞	U+23D7	Triseme
⏞⏞⏞	U+23D8	Tetraseme
⏞⏞⏞⏞	U+23D9	Pentaseme

## Arrows

---

↑	U+EB60	arrowBlackUp
↗	U+EB61	arrowBlackUpRight
→	U+EB62	arrowBlackRight
↘	U+EB63	arrowBlackDownRight
↓	U+EB64	arrowBlackDown
↙	U+EB65	arrowBlackDownLeft
←	U+EB66	arrowBlackLeft
↖	U+EB67	arrowBlackUpLeft
↕	U+F6D8	arrowBlackUpDown
↔	U+F6D9	arrowBlackLeftRight
↑	U+EB68	arrowWhiteUp
↗	U+EB69	arrowWhiteUpRight
→	U+EB6A	arrowWhiteRight
↘	U+EB6B	arrowWhiteDownRight
↓	U+EB6C	arrowWhiteDown
↙	U+EB6D	arrowWhiteDownLeft
←	U+EB6E	arrowWhiteLeft
↖	U+EB6F	arrowWhiteUpLeft
↕	U+F6DA	arrowWhiteUpDown
↔	U+F6DB	arrowWhiteLeftRight
↑	U+EB70	arrowOpenUp
↗	U+EB71	arrowOpenUpRight
→	U+EB72	arrowOpenRight
↘	U+EB73	arrowOpenDownRight
↓	U+EB74	arrowOpenDown
↙	U+EB75	arrowOpenDownLeft
←	U+EB76	arrowOpenLeft
↖	U+EB77	arrowOpenUpLeft
↕	U+F6DC	arrowOpenUpDown
↔	U+F6DD	arrowOpenLeftRight

## Arrows

	U+2191	Simple arrow .....	
	U+2197		
	U+2192		
	U+2198		
	U+2193		
	U+2199		
	U+2190		
	U+2196		
	U+2195		
	U+2922		
	U+2194		
	U+2921		
	U+21D1		Double arrow .....
	U+21D7		
	U+21D2		
	U+21D8		
	U+21D3		
	U+21D9		
	U+21D0		
	U+21D6		
	U+21D5		
	U+21D4		
	U+2B06	Black arrow .....	
	U+2B08		
	U+2B95		
	U+2B0A		
	U+2B07		
	U+2B0B		
	U+2B05		
	U+2B09		
	U+2B0D		
	U+2B0C		

## Arrows

↕	U+21E7	White arrow
↗	U+2B00	⋮
⇒	U+21E8	⋮
↘	U+2B02	⋮
⇓	U+21E9	⋮
↙	U+2B03	⋮
⇐	U+21E6	⋮
↖	U+2B01	⋮
↕	U+21F3	⋮
⇔	U+2B04	⋮
↑	U+2B61	Triangle-headed arrow
↗	U+2B67	⋮
→	U+2B62	⋮
↘	U+2B68	⋮
↓	U+2B63	⋮
↙	U+2B69	⋮
←	U+2B60	⋮
↖	U+2B66	⋮
↕	U+2B65	⋮
⇔	U+2B64	⋮
↗	U+2B71	Triangle-headed arrow to bar
↘	U+2B77	⋮
→	U+2B72	⋮
↘	U+2B78	⋮
↓	U+2B73	⋮
↙	U+2B79	⋮
←	U+2B70	⋮
↖	U+2B76	⋮
↕	U+F6DE	⋮
⇔	U+F6DF	⋮

## Arrows

↗	U+290A	Triple arrow
⇒	U+21DB	⋮
⇩	U+290B	⋮
⇐	U+21DA	⋮
↗↗	U+27F0	Quadruple arrow
⇒⇒	U+2B46	⋮
⇩⇩	U+27F1	⋮
⇐⇐	U+2B45	⋮
↕	U+2BED	Two-headed arrow
→→	U+2BEE	⋮
↓↓	U+2BEF	⋮
←←	U+2BEC	⋮
↔	U+21E1	Dashed arrow
→→	U+21E2	⋮
↓↓	U+21E3	⋮
←←	U+21E0	⋮
↔	U+2B6B	Triangle-headed dashed arrow
→→	U+2B6C	⋮
↓↓	U+2B6D	⋮
←←	U+2B6A	⋮
→→	U+290D	Double dash arrow
←←	U+290C	⋮
→→	U+290F	Triple dash arrow
←←	U+290E	⋮
→→	U+2911	Dotted arrow
←←	U+2B38	⋮
↔	U+21DD	Squiggle arrow
↔	U+21DC	⋮

## Arrows





















→	U+27F6	Long arrow
←	U+27F5	⋮
↔	U+27F7	⋮
⇒	U+27F9	Long double arrow
⇐	U+27F8	⋮
↔	U+27FA	⋮
↗	U+27FF	Long squiggle arrow
↖	U+2B33	⋮
➔	U+27A1	Black arrow
➡	U+2799	Heavy arrow
➞	U+2794	Heavy wide-headed arrow
➜	U+279C	Heavy round-tipped arrow
➞	U+279D	Triangle-headed arrow
➞	U+279E	Heavy triangle-headed arrow
➞	U+279F	Dashed triangle-headed arrow
➞	U+27A0	Heavy dashed triangle-headed arrow
➞	U+27B5	Black-feathered arrow
➞	U+27B3	White-feathered arrow
➞	U+27B8	Heavy black-feathered arrow
➞	U+27BE	Open-outlined rightwards arrow
➞	U+279B	Drafting point arrow
▶	U+25BA	Black pointer
◀	U+25C4	⋮
▽	U+25BB	White pointer
△	U+25C5	⋮

## Multiple arrows

















↕	U+21C5	Opposite arrows
↔	U+21C4	⋮
↕	U+21F5	⋮
↔	U+21C6	⋮
↕	U+2B81	Triangle-headed opposite arrows
↔	U+2B82	⋮
↕	U+2B83	⋮
↔	U+2B80	⋮
↕	U+21C8	Paired arrows
⇒	U+21C9	⋮
⇓	U+21CA	⋮
⇐	U+21C7	⋮
↕	U+2B85	Triangle-headed paired arrows
⇒	U+2B86	⋮
⇓	U+2B87	⋮
⇐	U+2B84	⋮
⇒⇒	U+21F6	Three arrows right



## Bent and curved arrows

	U+21B0	Arrow with bent tip
	U+21B1	
	U+2B0F	
	U+2B0E	
	U+21B3	
	U+21B2	
	U+2B10	
	U+2B11	
	U+2BA2	Triangle-headed arrow with long bent tip
	U+2BA3	
	U+2BA5	
	U+2BA7	
	U+2BA1	
	U+2BA0	
	U+2BA6	
	U+2BA4	
	U+2934	Curving arrow
	U+2935	
	U+2937	
	U+2936	

## Circle and arc arrows

	U+2938	Clockwise right arc arrow
	U+2939	Anticlockwise left arc arrow
	U+293A	Anticlockwise top arc arrow
	U+293B	Anticlockwise bottom arc arrow
	U+21B7	Clockwise top semicircle arrow
	U+21B6	Anticlockwise top semicircle arrow
	U+293E	Clockwise lower semicircle arrow
	U+293F	Anticlockwise lower semicircle arrow
	U+21BB	Clockwise circle arrow
	U+21BA	Anticlockwise circle arrow
	U+2B6E	Clockwise triangle-headed circle arrow
	U+2B6F	Anticlockwise triangle-headed circle arrow
	U+27F3	Clockwise gapped circle arrow
	U+27F2	Anticlockwise gapped circle arrow
	U+2941	Clockwise closed circle arrow
	U+2940	Anticlockwise closed circle arrow

## Arrowheads

▲	U+EB78	arrowheadBlackUp
↗	U+EB79	arrowheadBlackUpRight
▶	U+EB7A	arrowheadBlackRight
↘	U+EB7B	arrowheadBlackDownRight
▼	U+EB7C	arrowheadBlackDown
↙	U+EB7D	arrowheadBlackDownLeft
◀	U+EB7E	arrowheadBlackLeft
↖	U+EB7F	arrowheadBlackUpLeft
△	U+EB80	arrowheadWhiteUp
↗	U+EB81	arrowheadWhiteUpRight
▷	U+EB82	arrowheadWhiteRight
↘	U+EB83	arrowheadWhiteDownRight
▽	U+EB84	arrowheadWhiteDown
↙	U+EB85	arrowheadWhiteDownLeft
◀	U+EB86	arrowheadWhiteLeft
↖	U+EB87	arrowheadWhiteUpLeft
^	U+EB88	arrowheadOpenUp
↗	U+EB89	arrowheadOpenUpRight
>	U+EB8A	arrowheadOpenRight
↘	U+EB8B	arrowheadOpenDownRight
∨	U+EB8C	arrowheadOpenDown
↙	U+EB8D	arrowheadOpenDownLeft
<	U+EB8E	arrowheadOpenLeft
↖	U+EB8F	arrowheadOpenUpLeft

## Arrowheads

▲	U+2B9D	Black equilateral arrowhead
↖	U+F62C	⋮
➤	U+2B9E	⋮
▲	U+F62D	⋮
↙	U+2B9F	⋮
▶	U+F62E	⋮
↗	U+2B9C	⋮
↘	U+F62F	⋮
▲	U+2B99	Three-d equilateral arrowhead
↖	U+F628	⋮
➤	U+2B9A	⋮
▲	U+F629	⋮
↙	U+2B9B	⋮
▶	U+F62A	⋮
↗	U+2B98	⋮
↘	U+F62B	⋮
⤴	U+2303	Up arrowhead, Control
⤵	U+2304	Down arrowhead
➤	U+27A2	Three-d top-lighted rightwards arrowhead
➤	U+27A3	Three-d bottom-lighted rightwards arrowhead
➤	U+27A4	Black rightwards arrowhead

## Stars and marks

---

★	U+2605	Black star
☆	U+2606	White star
☆	U+2729	Stress outlined white star
⬤	U+272A	Circled white star
★	U+272B	Open centre black star
☆	U+272C	Black centre white star
☆	U+272D	Outlined black star
★	U+272F	Pinwheel star
☆	U+2730	Shadowed white star
☆	U+2B50	White medium star
★	U+2B51	Black small star
☆	U+2B52	White small star
☆	U+26E4	Pentagram
⬇	U+26E7	Inverted pentagram
✦	U+2726	Black four pointed star
✧	U+2727	White four pointed star
✦	U+2BCC	Four pointed black cusp
✧	U+2BCD	Rotated four pointed black cusp
✧	U+2BCE	White four pointed cusp
✧	U+2BCF	Rotated white four pointed cusp
✦	U+2722	Four teardrop-spoked asterisk
✕	U+274C	Cross mark
★	U+2736	Six pointed black star
✳	U+2731	Heavy asterisk
✳	U+273B	Teardrop-spoked asterisk
✳	U+2734	Eight pointed black star
✳	U+2733	Eight spoked asterisk
★	U+2737	Eight pointed rectilinear black star
★	U+2738	Heavy eight pointed rectilinear black star

## Stars and marks



U+2691 Black flag



U+2690 White flag



U+1F588 Black pushpin



U+1F4CC White pushpin



U+2318 Place of interest

































U+2316 Position indicator



































U+2BD0 Square position indicator

Geometric shapes



























	U+2B24	Black large circle
	U+25CF	Black circle
	U+26AB	Black medium circle
	U+25EF	White large circle
	U+25CB	White circle
	U+26AA	White medium circle
	U+26AC	White medium small circle
	U+25E6	White bullet
	U+2B55	Heavy large circle
	U+1F53E	Lower right shadowed circle
	U+1F53F	Upper right shadowed circle
	U+25CC	Dotted circle
	U+25C9	Fisheye
	U+25CE	Bullseye
	U+25CD	Circle with fill
	U+2BCA	Black half circle
	U+25D7	⋮
	U+2BCB	⋮
	U+25D6	⋮
	U+25D3	Circle with half black
	U+25D1	⋮
	U+25D2	⋮
	U+25D0	⋮
	U+25D4	Circle with one quarter black
	U+25D5	Circle with three quarters black
	U+25E0	Half circle
	U+25E1	⋮
	U+25DD	Quarter circle
	U+25DE	⋮
	U+25DF	⋮
	U+25DC	⋮

## Geometric shapes

































	U+25B2	Black triangle
	U+25B6	⋮
	U+25BC	⋮
	U+25C0	⋮
	U+25E5	⋮
	U+25E2	⋮
	U+25E3	⋮
	U+25E4	⋮
	U+25B3	White triangle
	U+25B7	⋮
	U+25BD	⋮
	U+25C1	⋮
	U+25F9	⋮
	U+25FF	⋮
	U+25FA	⋮
	U+25F8	⋮
	U+1F53A	Red triangle
	U+1F53B	⋮
	U+2BC5	Black medium triangle centred
	U+2BC8	⋮
	U+2BC6	⋮
	U+2BC7	⋮
	U+25B4	Black small triangle
	U+25B8	⋮
	U+25BE	⋮
	U+25C2	⋮
	U+25B5	White small triangle
	U+25B9	⋮
	U+25BF	⋮
	U+25C3	⋮
	U+1F53C	Red small triangle
	U+1F53D	⋮





























## Geometric shapes

	U+25EC	Triangle with dot
	U+25ED	Triangle with half black
	U+25EE	...
	U+2B1B	Black large square
	U+25A0	Black square
	U+25FC	Black medium square
	U+25FE	Black medium small square
	U+25AA	Black small square
	U+2B1D	Black very small square
	U+2B1C	White large square
	U+25A1	White square
	U+25FB	White medium square
	U+25FD	White medium small square
	U+25AB	White small square
	U+2B1E	White very small square
	U+25A4	Square with fill
	U+25A5	...
	U+25A6	...
	U+25A7	...
	U+25A8	...
	U+25A9	...
	U+2B12	Square with half black
	U+25E8	...
	U+2B13	...
	U+25E7	...
	U+2B14	...
	U+25EA	...
	U+2B15	...
	U+25E9	...















## Geometric shapes

	U+25A2	Rounded square
	U+2B1A	Dotted square
	U+25A3	Square with small square
	U+25EB	Square with vertical line
	U+25AC	Black rectangle
	U+25AE	⋮
	U+25AD	White rectangle
	U+25AF	⋮
	U+25B0	Black parallelogram
	U+25B1	White parallelogram
	U+25C6	Black diamond
	U+2B25	Black medium diamond
	U+2B29	Black small diamond
	U+25C7	White diamond
	U+2B26	White medium diamond
	U+25C8	Diamond with small diamond
	U+2B18	Diamond with half black
	U+2B17	⋮
	U+2B19	⋮
	U+2B16	⋮
	U+2B27	Black medium lozenge
	U+2B2A	Black small lozenge
	U+25CA	White lozenge
	U+2B28	White medium lozenge
	U+2B2B	White small lozenge
	U+2B1F	Black pentagon
	U+2B53	⋮
	U+2B20	White pentagon
	U+2B54	⋮
	U+2B22	Black hexagon
	U+2B23	⋮
	U+2B21	White hexagon

## Miscellaneous symbols

	U+EC60	miscDoNotPhotocopy
	U+EC61	miscDoNotCopy
	U+26A0	Warning sign
	U+2757	Heavy exclamation mark
	U+2755	White exclamation mark
	U+2753	Black question mark
	U+2754	White question mark
	U+2BD1	Uncertainty sign
	U+EC62	miscEyeglasses
	U+F65F	miscEyeglassesRight
	U+1F50D	Magnifying glass left, Search
	U+1F50E	Magnifying glass right, More details
	U+1F440	Eyes
	U+1F441	Eye, Sight
	U+1F442	Ear
	U+1F44B	Waving hand
	U+1F44F	Clapping hands
	U+1F464	Bust in silhouette
	U+1F465	Busts in silhouette
	U+1F56E	Book
	U+1F4D6	Open book, Read
	U+1F4D5	Closed book
	U+1F3F7	Label, Tag
	U+223F	Sine wave, Alternating current
	U+1F50C	Electric plug
	U+1F50B	Battery
	U+1FAAB	Low Battery

## Miscellaneous symbols

	U+2307	Wavy line
	U+27B0	Curly loop
	U+27BF	Double curly loop
	U+221E	Infinity
	U+223C	Tilde
	U+223D	Reversed tilde
	U+223E	Inverted lazy S
	U+2248	Almost equal to, Circa
	U+2249	Not almost equal to
	U+224A	Almost equal or equal to
	U+224B	Triple tilde
	U+2591	Light shade (25%)
	U+2592	Medium shade (50%)
	U+2593	Dark shade (75%)
	U+2588	Full block (100%)

Basic Latin (ASCII)

---

!	U+0021	exclam
"	U+0022	quotedbl
#	U+0023	numbersign
\$	U+0024	dollar
%	U+0025	percent
&	U+0026	ampersand
'	U+0027	quotesingle
(	U+0028	parenleft
)	U+0029	parenright
*	U+002A	asterisk
+	U+002B	plus
,	U+002C	comma
-	U+002D	hyphen
.	U+002E	period
/	U+002F	slash
0	U+0030	zero
1	U+0031	one
2	U+0032	two
3	U+0033	three
4	U+0034	four
5	U+0035	five
6	U+0036	six
7	U+0037	seven
8	U+0038	eight
9	U+0039	nine
:	U+003A	colon
;	U+003B	semicolon
<	U+003C	less
=	U+003D	equal
>	U+003E	greater
?	U+003F	question

## Basic Latin (ASCII)





@	U+0040	at
A	U+0041	A
B	U+0042	B
C	U+0043	C
D	U+0044	D
E	U+0045	E
F	U+0046	F
G	U+0047	G
H	U+0048	H
I	U+0049	I
J	U+004A	J
K	U+004B	K
L	U+004C	L
M	U+004D	M
N	U+004E	N
O	U+004F	O
P	U+0050	P
Q	U+0051	Q
R	U+0052	R
S	U+0053	S
T	U+0054	T
U	U+0055	U
V	U+0056	V
W	U+0057	W
X	U+0058	X
Y	U+0059	Y
Z	U+005A	Z
[	U+005B	bracketleft
\	U+005C	backslash
]	U+005D	bracketright
^	U+005E	asciicircum
_	U+005F	underscore

## Basic Latin (ASCII)

`	U+0060	grave
a	U+0061	a
b	U+0062	b
c	U+0063	c
d	U+0064	d
e	U+0065	e
f	U+0066	f
g	U+0067	g
h	U+0068	h
i	U+0069	i
j	U+006A	j
k	U+006B	k
l	U+006C	l
m	U+006D	m
n	U+006E	n
o	U+006F	o
p	U+0070	p
q	U+0071	q
r	U+0072	r
s	U+0073	s
t	U+0074	t
u	U+0075	u
v	U+0076	v
w	U+0077	w
x	U+0078	x
y	U+0079	y
z	U+007A	z
{	U+007B	braceleft
	U+007C	bar
}	U+007D	braceright
~	U+007E	asciitilde
´	U+00B4	acute

## Spaces

---

	U+0020	space
	U+2002	enspace
	U+2003	emspace
	U+2009	thinspace
	U+200A	hairspace